

# licht.wissen 01

Lighting with Artificial Light



Free Download at  
[www.licht.de/en](http://www.licht.de/en)





# Editorial



*Light is as essential to us as the air we breathe. And our daily lives would now be inconceivable without artificial light.*

*Light has three functions for human beings. First of all it ensures that we can see well. Light also affects our emotional state because light and shade, colour and contrast help determine our mood. And there is also a third very important dimension: light influences our biological functions by acting as the basis of our body clock. Good lighting as based on the model of natural daylight is therefore important for our well-being and our health.*

*Static, inflexible lighting no longer meets these requirements. Modern lighting technology offers “smart” solutions which can provide greater support than ever before. Cold-white light in the office in the morning provides a boost of energy; on returning home, the lights come on automatically, based on system settings adjusted to the owners’ individual tastes. Street lights regulate the lighting level based on traffic and weather conditions and optimize energy consumption and visual comfort as required.*

*Driving this rapid development are energy-efficient LED solutions and digital lighting management systems. This duo guarantees huge energy savings and each new stage of development increases comfort levels for users.*

*One thing is certain: the days in which lamps simply “generate light” are over. Today, lighting offers more exciting possibilities than ever before. But how can users find exactly the right solution? What should they take into consideration when planning the lighting? This booklet, licht.wissen 01, aims to answer these questions. It provides a basic introduction to lighting technology for everyone interested in the subject of light – and raises awareness of the characteristics of good lighting.*

*The booklet is also the first in the series of licht.de publications. This series aims to help anyone involved in the planning of lighting who wants to find out about different solutions for a wide range of applications – from street lighting and lighting in industry, schools and offices through to home lighting. More information about light and lighting can be found at [www.licht.de](http://www.licht.de).*

Dr. Jürgen Waldorf  
Manager Director of licht.de,  
an industry initiative of ZVEI e.V.





**From natural light to light when we need it**  
Page 6



**What is light?**  
Page 8

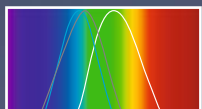

**Light and our eyes**  
Page 10



**Lighting technology terms**  
Page 12



**Quality characteristics of lighting**  
Page 15



**Lighting level and maintained illuminance**  
Page 16



**Limiting direct glare**  
Page 18



**Avoiding glare by reflection**  
Page 20



**Brightness distribution**  
Page 22



**Direction of light and modelling**  
Page 24



**Light colour – From warm to cool**  
Page 26



**Colour rendering**  
Page 28



**Light generation in the 21st century**  
Page 30





## Light sources

Page 34



## Luminaires: Selection and light distribution

Page 36

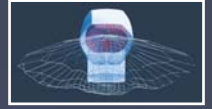

## Certification marks and protection symbols

Page 38



## Luminaires and their power supply units

Page 40



## Luminaires in use

Page 42



## Lighting design

Page 44



## Lighting management

Page 46



## Energy-efficient lighting

Page 48



## Sustainable lighting technology

Page 50



## Lighting costs

Page 52



## Measuring lighting systems

Page 54



## Standards and literature

Page 56



## Publications, Imprint

Page 58







## From natural light to light when we need it

Light is life – and essential for people, animals and plants. For a long time, before people were able to use artificial light, natural daylight was the only light available. Modern lighting concepts combine both light sources – for our improved well-being and health.

We use our eyes for orientation – our environment is the world we see around us. We take in more than 80 percent of all information through our eyes; they are our most important sensory organ. Without light, this would be impossible: light is the medium that makes visual perception possible.

### Light is quality of life

Insufficient light or darkness prevent good vision: we feel unsafe and lose our bearings. Only with good lighting do we feel safe.

And so light not only enables us to see, it also affects our mood and sense of well-being. Moreover, since the turn of the millennium we know that natural daylight and how it changes during the day and the year also affects our hormone levels and controls our circadian rhythm. The right lighting thus contributes to our health and our quality of life.

### In the beginning there was fire...

For a long time the sun was humanity's only source of light. About 300,000 years ago man began using fire as a source of heat and light. Glowing flames allowed people

to live in caves which the rays of the sun could never penetrate. The cave drawings in Altamira, for example, can only have been created some 15,000 years ago in artificial light. Light from camp fires, kindling torches and oil and tallow lamps was a significant achievement in the everyday life of prehistoric man.

But light was not only created in enclosed spaces: the Lighthouse of Alexandria was built in around 260 BC, and there is evidence of "lights in the streets" in Antioch, i.e. of street lighting, in 378 AD.

From a very early stage, people began to design ornamental yet functional holders of the precious light-giving flame. However, there were no significant improvements in the liquid-fuel lamps which were used for thousands of years until 1783 when Aimé Argand invented the central burner.

In that same year a technique discovered by Minckelaers was used to obtain "coal gas" for gas lanterns. Almost at the same time, the first experiments were being conducted with electric arc lamps. However, these only gained practical significance in



05



06

1866 when Werner Siemens succeeded in generating electricity in an economically viable way using dynamos. But the real dawn of the age of electric light came in 1879 with Thomas Alvar Edison's "reinvention" and technological application of the incandescent lamp invented 25 years earlier in 1854 by the German clock-maker Johann Heinrich Goebel.

### Lamps, LEDs and lighting control

The goal has always been to increase the luminous efficacy of lamps and to find ways of improving luminaires. Incandescent lamps were followed by halogen lamps and the first discharge lamps. Until well into the 1980s the main focus of the technical development was on producing ever more efficient fluorescent lamps and electronic ballasts.

The first LEDs were launched in the mid-1990s – and rapidly changed the world of lighting. LEDs are extremely efficient, durable, can be linked together and precision-controlled. Almost half of all outdoor lamps today and over 30 per cent of luminaires for indoor use are equipped with LED modules (2015 figures, ZVEI). Light has become increasingly dynamic as a result.

The switch to LED lighting and the development of intelligent light control systems are not only the key to extremely energy-efficient lighting solutions, they also open up completely new applications that were previously inconceivable – and thus a

wealth of possibilities for adapting lighting more effectively than ever before to people's functional, emotional and biological needs.

### The three-fold effect of light

**Light for visual functions** – ensures unimpaired vision which is glare-free and easy on the eyes.

**Light with a biological effect** – supports the circadian rhythm, has an energising or relaxing impact.

**Light used for emotional effect** – enhances architecture and space, shaping it and improving the aesthetic impact.

[02 + 03] Light from the sun changes over the course of the year and determines the rhythm of life with its change from day to night. Sunlight illuminance levels reach about 100,000 lux, with roughly 0.2 lux being measured on a moonlit night.

[04] The first light source was fire.

[05 – 07] Artificial light has given people security and orientation for more than 2,000 years – today in the form of efficient LED lamps and convenient lighting management.



07



08

## What is light?

Minute particles – maximum effect! Light is one of the great wonders of the universe. The ancient Greeks pondered the phenomenon, as have many famous scientists – from Isaac Newton to Albert Einstein – since then.

People have always been fascinated by light and have constantly striven to unravel its mysteries. In ancient Greece, Aristotle believed that light moved in a similar way to water waves. Pythagoras (c. 570 – 480 BC), on the other hand, was convinced that the human eye emitted “hot visual rays” which were “repelled” by other objects. Of course, if this theory were true, we would be able to see in the dark...

### As fast as it gets: Light

Pupils learning physics today are taught that light is to be understood both as a wave and as a particle – and that it travels incredibly quickly. Turn on the switch, and the light comes on immediately. Back in 1675 the Dane Ole Christensen Rømer calculated with astonishing accuracy the speed of light, based on his observations of the moons of Jupiter discovered by Galileo Galilei:  $2.3 \times 10^8$  m/s.

The measurements of the speed of light made by Leon Foucault in 1850 at  $2.98 \times 10^8$  m/s were even more precise. In other words: we now know that light travels at just under 300,000 kilometres per second in air or a vacuum. Accordingly, the sunlight reflected by the moon reaches us in approximately 1.3 seconds, with the light of the sun itself taking roughly 8½ minutes.

### Of waves and particles

The propagation of light can usefully be described on the basis of light beams: light from a point light source bends upon entering a narrow slit. A linear pattern is created behind the slit.

Back in the 17th century Christiaan Huygens developed the wave theory of light, in which light moves in a similar way to a water wave. Almost at the same time, Isaac Newton put forward the theory that light consists of tiny particles or corpuscles and travels in straight lines. For a long time scientists disagreed on whose theory was correct...

In the 19th century James Clerk Maxwell declared light to be an electromagnetic wave consisting of electrical and magnetic

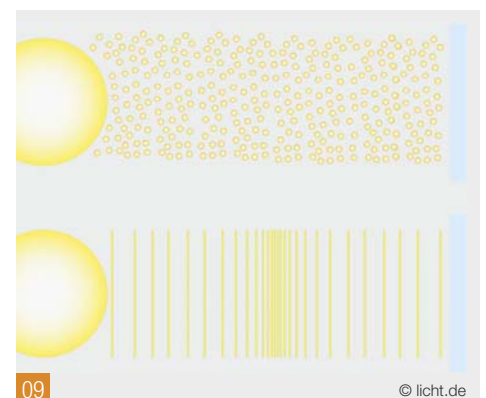

© licht.de

[08] Impressive light: A rainbow features all the colours of the spectrum; drops of water refract the light.

[09] Both the corpuscular and wave models are now used to explain the properties of light.



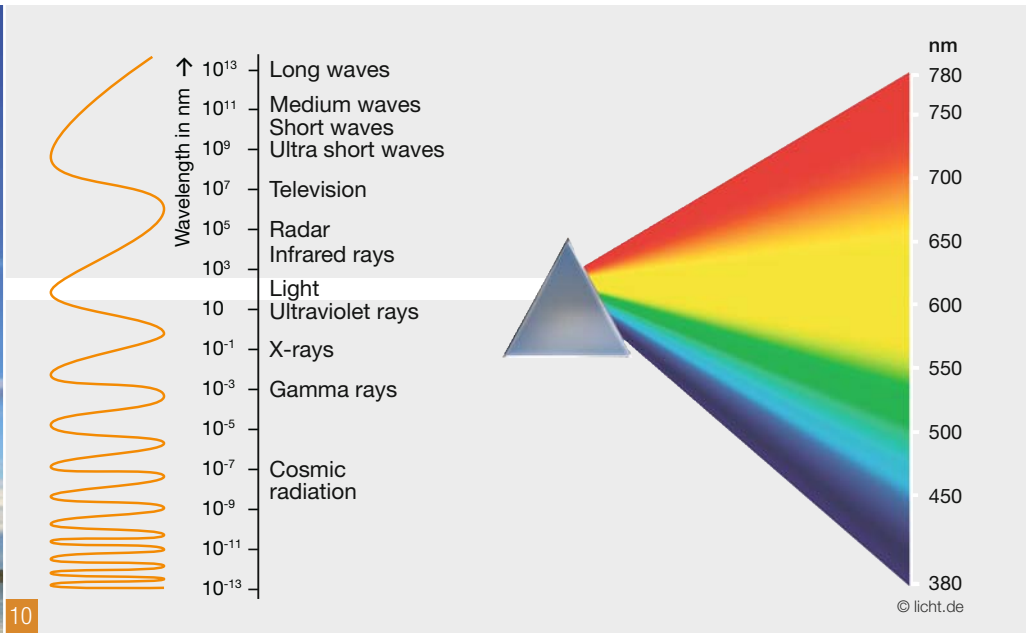

fields which can change over time and space. The Maxwell theory paved the way for global electrification. It was Albert Einstein's Theory of Relativity that finally brought together the two competing approaches – the wave and corpuscular model. This states that light is a wave that is emitted in small bursts (= quanta). In other words: light is the visible part of electromagnetic radiation made up of oscillating energy quanta.

Max Planck describes the quantum theory using the formula:

$$E = h \cdot \nu$$

The energy E of an energy quantum (of radiation) is proportional to its frequency  $\nu$ , multiplied by a constant h (Planck's constant).

### Visible light

In fact, the human eye is only capable of perceiving a relatively small range of the electromagnetic spectrum (see also page 10f.). The wavelength of visible radiation is between 380 nm and 780 nm (1 nanometre =  $10^{-9}$  m). Electromagnetic radiation includes light waves and also x-rays.

### Every colour of the spectrum

It was Newton who discovered that sunlight contains colours. If a narrow light beam is directed at a glass prism and the exiting rays are projected onto a white surface, a spectrum of colours appears. This can also be seen to gratifying effect in nature when a rainbow appears in the sky.

Each colour corresponds to a particular wavelength. The spectrum of sunlight transitions from short-wavelength blue (< 450 nm) via green and yellow to long-wavelength red (> 600 nm). The mixture of all colours produces white light.

Natural colours are relative because we only see the colours that are reflected in a particular lighting situation. As a result, coloured items can only be properly detected if all colours are present in the spectrum of the light source. This is the case with sunlight, halogen lamps or LEDs with very good colour rendering properties (see also page 28f.).

### IR and UV radiation

Above and below the visible range of the radiation spectrum lie the infrared (IR) and ultraviolet (UV) ranges.

The IR range encompasses wavelengths between 780 nm and 1 mm. Not until IR radiation falls upon an object is it absorbed and converted into heat. Without this heat radiation from the Sun, the Earth would be a frozen planet. Sunlight also plays an important role in alternative energy production, for example in the field of photovoltaics and solar technology.

The right amount of UV radiation is vital for life on Earth. The following ranges are defined based on their biological effect

- UV-A (315 to 380 nm)  
= Tanning of the skin
- UV-B (280 to 315 nm)  
= Reddening of the skin (erythema), sunburn

- UV-C (100 to 280 nm)  
= Cell destruction, germicidal lamps;

There are positive effects of ultraviolet radiation (for example, UV-B for vitamin D synthesis), yet excessive exposure may result in damage. The Earth's atmosphere protects us from a surfeit of cosmic radiation. It reduces light, UV and IR radiation to a level which makes organic life possible.

[10] Light is the small section of electromagnetic radiation that is visible to the human eye. If "white" sunlight is directed through a prism, its spectral colours appear. These have different wavelengths.

### Sensitive ganglion cells

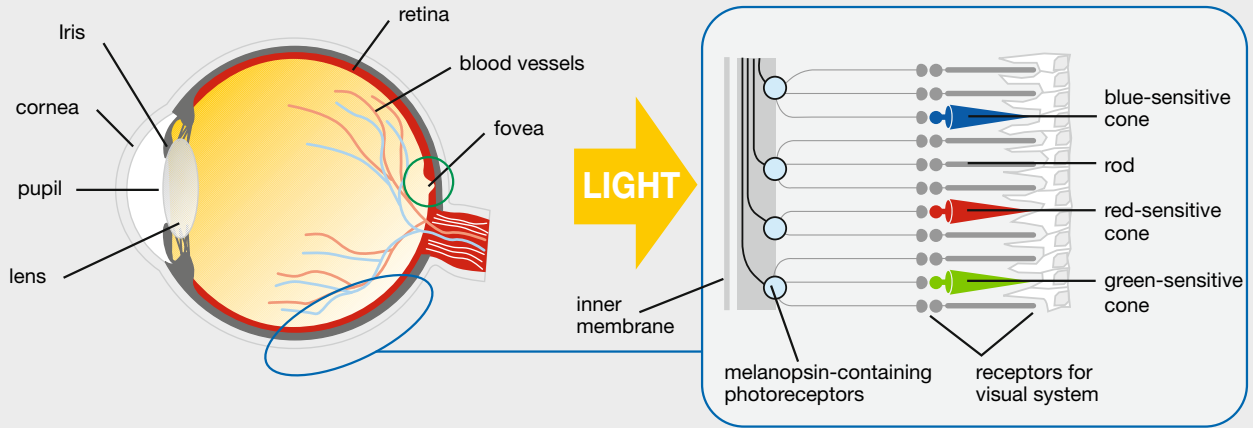

○ Photoreceptors for daytime vision are particularly concentrated in the fovea (the small depression at the centre of the retina responsible for sharpness of vision, Ø~1.5 mm). The area contains around 60,000 cones but no rods.

○ Melanopsin-containing ganglion cells are distributed over the entire retina; the most sensitive are in the lower and nasal areas.

© licht.de

11

## Light and our eyes

The human eye is an amazing instrument: our visual sense operates in a similar way to a camera and provides us with roughly 80 per cent of the information we receive about our surroundings. The non-visual effects of light are also registered; these create a sense of well-being and can boost our performance.

Our eyes can distinguish between roughly 150 shades of colour in the visible light spectrum and combine them to create half a million colour values. The eyes absorb the electromagnetic light waves and transform them into a series of nerve impulses that are then sent to the brain. That is where the actual image of our surroundings is created.

Part of the spherical eyeball (or “bulbus oculi”, to give it its technical name) works like a camera. At the front of the eye is the transparent cornea which is about half a millimetre thick. It serves the same function as a window, i.e. to let light in. The image-forming optics also include the lens and the intervening aqueous humour that fills the cavities of the eye and which is continually replaced. Behind the cornea is the ring-shaped iris. Using two muscles it can dilate or contract the pupil – its central opening – like a camera shutter to control the amount of incident light in a range of approximately 1:16 and improve the depth of field.

The eye lens, located behind the pupil, focuses the incident light. In a healthy eye it is transparent and clear. It is also elastic and can adjust the point of focus to different distances by changing its curvature. This ability is called accommodation. It

decreases with age as the result of progressive hardening of the lens tissue.

Once the light has passed through the cornea, pupil and the lens body it falls on the retina. This is the “projection screen” and contains about 130 million photoreceptor cells. The parallel incoming light rays are bundled to converge precisely on the fovea. The lens and vitreous body produce inverted images of the world around us which the brain then “corrects” in real time. The visual cells for daytime and colour vision are particularly dense in the fovea.

### Rods and cones for vision

Two types of photoreceptor cells – cones and rods – are responsible for vision depending on the brightness level. They have different spectral sensitivities. The roughly seven million cones react at higher brightness levels and are responsible for daylight and colour vision and allow sharply-focused vision. Their maximum spectral sensitivity is in the yellow-green range at 555 nm. Colour vision is made possible through the interaction of the three cone types with their different spectral sensitivities (red, green, blue).

In dim light we see only outlines and shades of grey. This is when the 120 million rod

[11] Rods and cones are responsible for vision. The eye contains a third light receptor which controls our “body clock”. These special photoreceptors are in the nasal and lower part of the retina and are especially sensitive to blue light.

## Light requirement and age

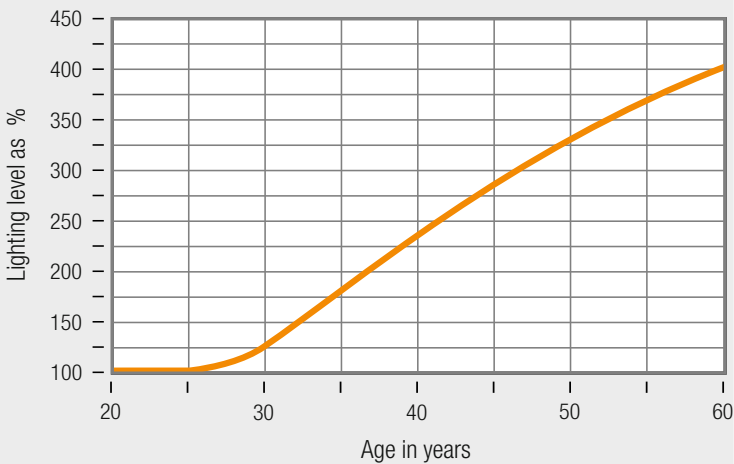

12

© licht.de

## Spectral response functions

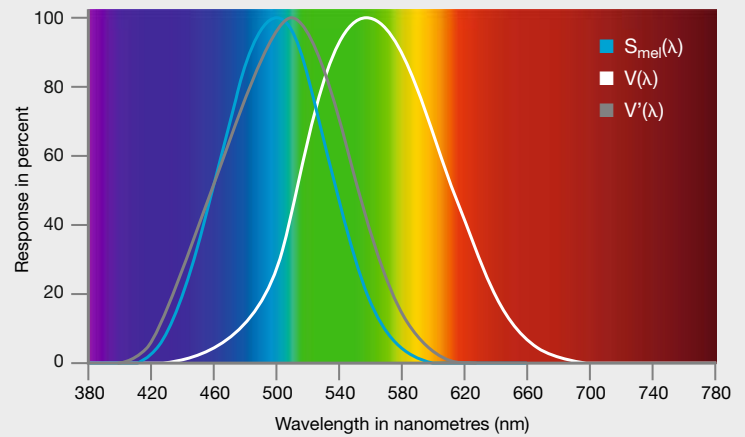

13

© licht.de

cells take over. These are highly sensitive to brightness but relatively insensitive to colour. They are used for night vision; their maximum spectral sensitivity lies in the blue-green range at 507 nm.

The ability of the eye to adjust to higher or lower levels of luminance is termed adaptation. The adaptive capacity of the eye extends over a luminance range of 1 to 10 billion. The level of adaptation determines the visual performance at any moment. Therefore, the higher the lighting level, the better the visual performance and the fewer vision problems there are. The level of adaptation depends on the luminance at the beginning and at the end of a change in light intensity.

Adaptation to darkness takes longer than adaptation to light. The eye needs about 30 minutes to adapt to the darkness outdoors at night after the brightness of a workroom. The time needed to adapt to brighter conditions, however, is only seconds.

Visual acuity depends not only on the adaptation capacity but also on the resolving power of the retina and the quality of

the optical image. Reasons for insufficient visual acuity can be eye defects such as short-sightedness, but also inadequate lighting with insufficient contrast or illumination levels. In general, more light is needed as people get older. The lens yellows with age, the perception of colour and depth decrease and the eyes find it harder to adapt. Higher illuminance levels can help compensate for the weaker visual performance. A man of sixty therefore needs four times more light than a twenty year-old.

### The third light receptor

Recent studies show that the natural change from daylight to darkness controls many biological processes in the body. Light is therefore also responsible for how well we sleep and how we feel during the day. If this important timing mechanism is missing, our body clock gets out of sync. Fatigue, listlessness and even depression can result. Biologically effective lighting matches daylight with varying lighting levels and dynamically changing light colours (see also page 26f.).

At the beginning of the new millennium, scientists discovered a third light receptor in the retina. These special photoreceptors do not, however, help our vision. They contain the light-sensitive protein melanopsin and register only brightness. They are particularly sensitive to blue light with a wavelength of about 480 nm. In this case, they give the signal to suppress the sleep hormone melatonin. Morning daylight, on the other hand, ensures that people are alert during the day.

[12] Higher illuminance needed in old age: A man of sixty needs four times more light than a twenty year-old.

[13] Wavelength and effect: Action spectrum of melatonin suppression  $S_{mel}(\lambda)$  compared to the brightness sensitivity of the eye in daytime vision  $V(\lambda)$  and night-time vision  $V'(\lambda)$ .

[14] Adaptation of the eye: On leaving a bright room and entering a dark one, we at first see “nothing”. Only after a certain period of time do people and objects emerge clearly from the darkness.

## Seeing and discerning

There are at least four conditions for good vision.

1. In order to be seen, objects require a minimum luminance (adaptation luminance). Objects that can easily be made out in detail in bright daylight become indistinct at dusk and are no longer visible in the dark.
2. In order to discern an object, there must be a difference in brightness between the object itself and its immediate surroundings (minimum contrast). In most cases there is also a colour contrast and luminance contrast.
3. Objects must be above a minimum size.
4. There is a minimum time for perception. Slowly rotating wheels, for instance, can be seen in detail, but become increasingly blurred at higher rotation speeds.

Lighting designers have the task of creating good visual conditions by ensuring high luminance, sufficient contrast and uniform lighting within the field of vision.



14



# Lighting technology – Parameters and terms

Illuminance, luminous efficacy, maintenance factor. Planning a lighting system requires knowledge of the basic terms and parameters of lighting technology.

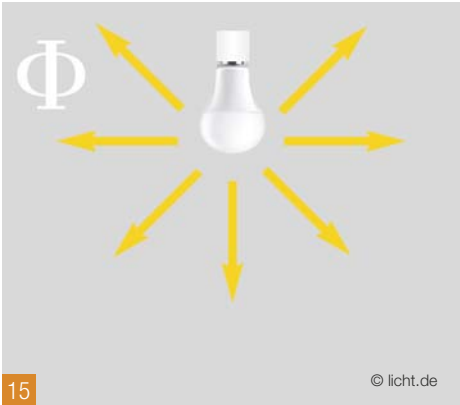

## Luminous flux $\Phi$

The luminous flux indicates how much light a light source emits in all directions. It describes the overall light output and is measured in lumens (lm).

The luminous flux is determined using special measuring devices or calculated mathematically. It is an indicator of the total brightness  $V(\lambda)$  of a luminaire as perceived by the human eye. DIN 5031-1 provides a

virtual average in the form of the V-lambda curve.

In the era of efficient LEDs, the lumen rating is increasingly replacing the wattage which was used in the past to indicate the brightness of a light bulb. In lighting design, the luminous flux of a luminaire (in contrast to the luminous flux of the lamp) includes losses arising from the luminaire design.

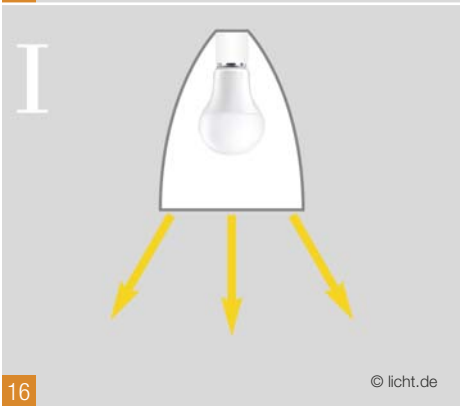

## Luminous intensity $I$

In order to calculate the distribution of light in a lighting system, it is not sufficient only to know the luminous flux; the distribution of the luminous flux in a particular angle must also be known. The luminous intensity is therefore the part of the luminous flux which radiates in a certain direction. It is measured in candelas (cd).

The luminous intensity distribution of reflector lamps and luminaires is shown in a polar diagram (luminous intensity distribution curves, IDCs).

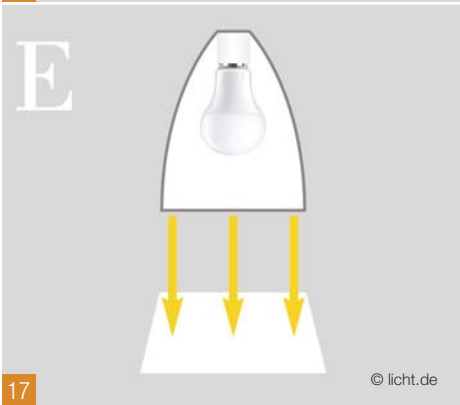

## Illuminance $E$

Illuminance ( $E$ ) describes how much light falls on a surface. The quotient of the luminous flux ( $= \Phi$ ) and the illuminated surface ( $= A$ ) is determined for this:  $E = \Phi/A$ . The unit for illuminance is lumen per square metre; it is given in lux (lx).

The illuminance can be calculated for any virtual plane in space or can simply be measured using a lux meter. In offices the working plane, e.g. the desk, is horizontal – light technicians speak here of a horizontal illumination area. In the case of shelving units or for facial recognition, on the other hand, vertical illumination is of importance.

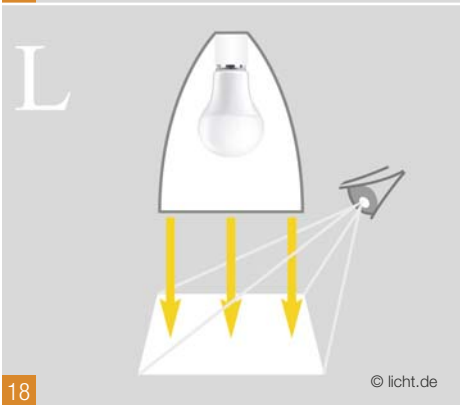

## Luminance $L$

Luminance can be perceived by the eye. It describes the impression of a surface's brightness as dictated by its colour and material. The unit of luminance is  $cd/m^2$ .

Luminance is used in outdoor lighting as a planning factor. For fully diffuse reflecting indoor surfaces, the luminance can be calculated in  $cd/m^2$  from the illuminance  $E$  in lux and the reflectance  $\rho$ :

$$L = \frac{\rho \cdot E}{\pi}$$

### Luminous efficacy $\eta$

The luminous efficacy is the measure of efficiency of light sources. It indicates how much energy must be applied to obtain a given luminous flux and is expressed in lumens per watt (lm/W). The higher this value, the more efficient the lamp. In practice, however, it is the efficiency of the entire system – including light source, luminaire, optics and power supply units – which is decisive. Very high luminous efficacy figures are sometimes given (especially for LEDs) which are obtained in the laboratory under ideal conditions and which cannot be reproduced in normal operation.

### Glare

Glare is annoying. It can be caused by lamps themselves, or indirectly by reflections on shiny surfaces.

Glare is dependent on

- the luminance and size of the light source
- its position relative to the observer
- the brightness of the surroundings and the background.

The correct positioning and shielding of lu-

minaires and the selection of bright colours and matt room surfaces can keep glare to a minimum; it is not, however, possible to prevent it entirely.

It is especially important to avoid direct glare in street lighting as this affects road safety. In the office it is important to prevent reflected glare on workstation screens in order to ensure a good ergonomic working environment (see also p. 18f. on the subject of glare).

### Reflectance $\rho$

The reflectance indicates the percentage of luminous flux reflected by a surface. It is an important factor in the calculation of interior lighting.

Dark surfaces require high illuminance, lighter surfaces need a lower illuminance level in order to produce the same impression of brightness.

The spatial distribution of reflected light is also an important planning factor in street lighting due to the directional reflectance (e.g. of a worn road surface).

### Maintained illuminance $\bar{E}_m$ and luminance $\bar{L}_m$

The visual tasks which are performed in a room are decisive for the required maintained illuminance values. These are the values below which the local mean illuminance values are not allowed to fall (see also page 16f.).

### Maintenance factor (MF) in lighting design

With increasing length of service, the illuminance and luminance decrease as a result of aging and soiling of lamps, luminaires and room surfaces.

According to the harmonized European standards, maintenance factors must be agreed between and documented by planners and operators. A maintenance plan for the lighting system should also be drawn up.

The maintained value and the maintenance factor determine the value required on installation: Maintained value = value on installation x maintenance factor.

### Uniformity

Excessive brightness differences strain the eyes, which is why a certain level of



illumination uniformity is stipulated in DIN EN 12464 for each visual task. Uniformity ( $U_0$ ) describes the ratio of minimum to mean illuminance ( $U_0 = E_{min}/E$ ), or, in street lighting, the ratio of minimum to mean luminance ( $U_0 = L_{min}/L$ ). DIN EN 12464-1 requires, for instance, a uniformity level of at least 0.1 on walls and ceilings.

**Lifetime**

The lifetime of a lamp is usually specified in hours. For LEDs, high-pressure discharge lamps as well as fluorescent and compact fluorescent lamps with plug-in base it is given as the **rated lifetime**.

All these light sources degrade, i.e. their brightness diminishes with operation. The rated lifetime (given as L) therefore describes the time in which the luminous flux of the light source falls to the specified value. For general lighting, typical values are  $L_{80}$  or  $L_{70}$ . Thus the average rated lifetime of an LED is reached when the luminous flux reaches 70 percent of its value at installation.

The degradation and failure of LEDs is determined essentially by the let-through current and the temperature inside the LED; in the case of modules, the electrical wiring of the LED, the ambient and operating temperature and further module characteristics also play a role.

 Further information on LEDs can be found in the ZVEI "Reliable Planning with LED Lighting" guide (download from [www.licht.de](http://www.licht.de)).

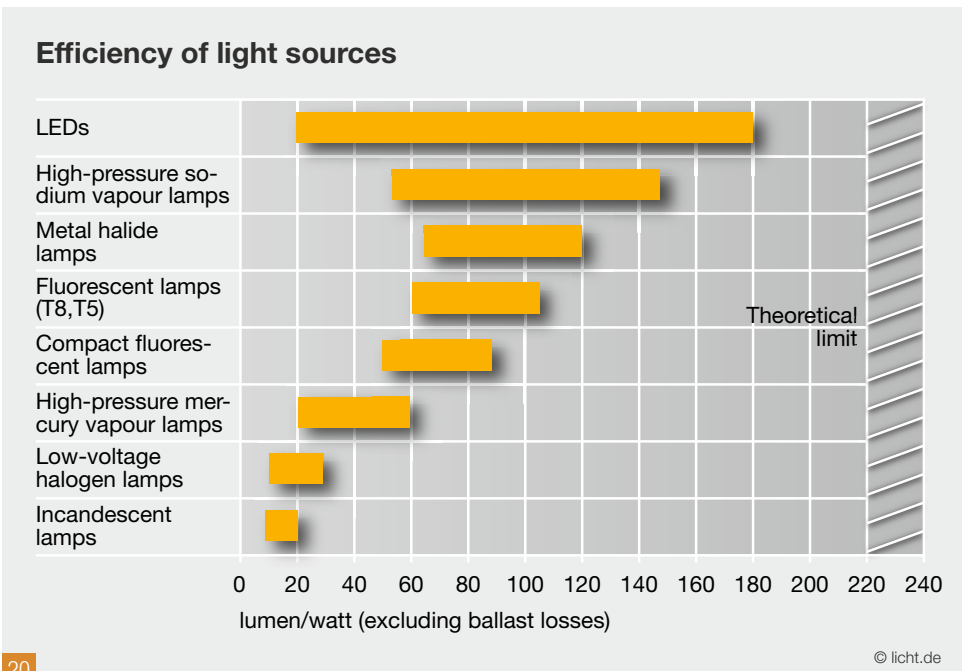

20

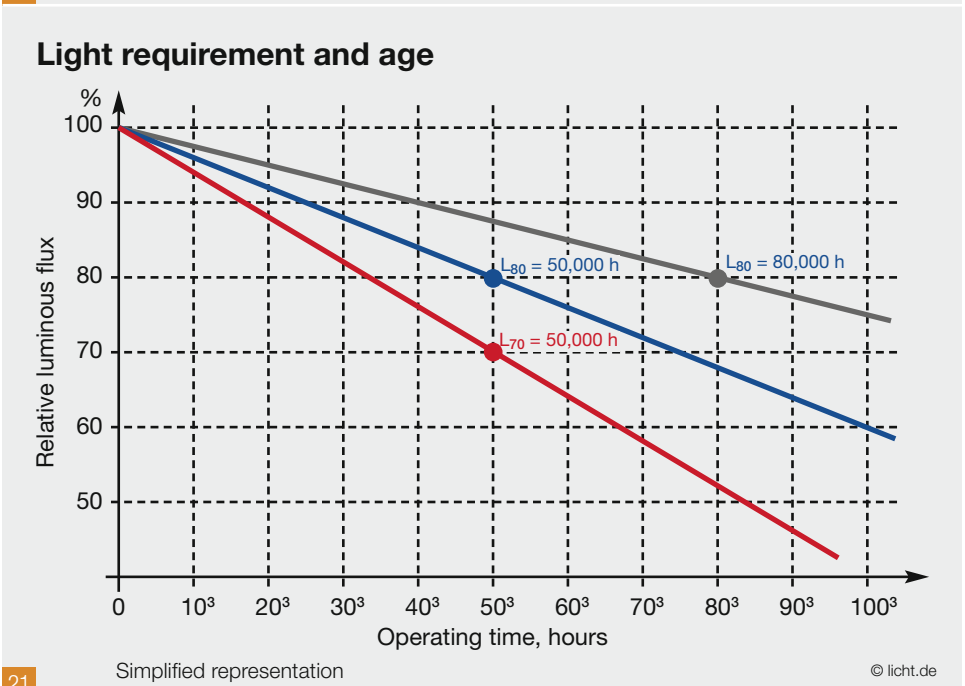

21

**Lighting standards**

Standards stipulate basic requirements for lighting. Most EN standards now apply throughout Europe.

Important European standards include:

- DIN EN 12464 for lighting of work places
- DIN EN 13201 for road lighting
- DIN EN 12193 for sports lighting
- DIN EN 1838 for emergency lighting
- DIN EN 12665 for basic terms and criteria for specifying lighting requirements.

[20] Modern light sources are becoming ever more efficient. In the laboratory, coloured LEDs are already achieving values of up to 300 lumens/watt.

[21] LEDs (and almost all discharge lamps) do not generally fail, rather their luminous power decreases over time. The lifetime is given as  $L_x$ . Typical examples of the proportion x (as %) of the rated luminous flux are e.g. 70 or 80 per cent (=  $L_{70}$  or  $L_{80}$ ) at a given rated lifetime of 50,000 hours and an ambient temperature of 25° C for the luminaire.



# Quality characteristics of lighting

The level of lighting design describes the quality of lighting. “Good lighting” is characterized by its meeting all or nearly all quality characteristics – including new requirements such as daylight integration and energy efficiency.

The lighting quality requirements are based on the visual tasks which need to be performed by the human eye. Reading, precision manual tasks, night-time driving or working at a computer: The visual tasks vary depending on the activity. And each situation makes special demands on the lighting.

The traditional quality characteristics of lighting can be divided into three basic quality features which are weighted differently depending on the use of space and the desired effect: visual performance, visual comfort and visual ambience. The following applies:

- The visual performance is influenced by the level of illumination and the limitation of direct glare and glare by reflection.
- Visual comfort is ensured by good colour rendering and harmonious brightness distribution in the space.
- Visual ambience is determined by light colour, light direction and modelling.

Good lighting can be achieved by natural or artificial light or a combination of both. Current systems also include other quality features (see Fig. 22) and take into consideration the visual, emotional and biological effects of light. Key characteristics:

- Adequate level of illumination
- Harmonious brightness distribution
- Limitation of direct glare and reflections
- Light direction and modelling in order to identify structures
- Light colour and colour rendering
- Lack of flicker and
- The possibility to change the lighting level and colour temperature.

Good lighting systems are also characterized by their high energy efficiency. However, DIN EN 12464-1 also stipulates that the quality of light should not be reduced in order to reduce energy consumption.

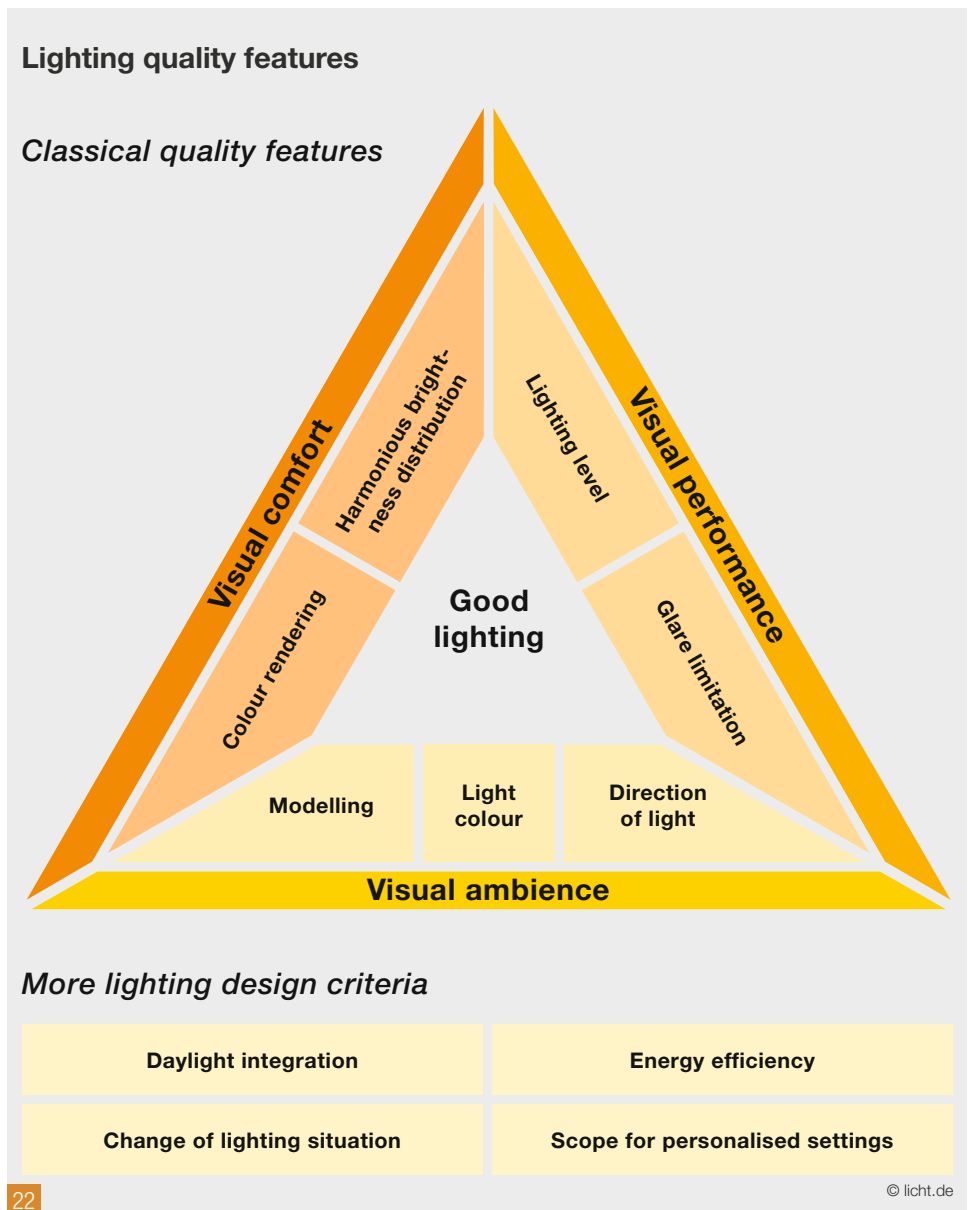

[22] Standards define quality characteristics that determine the overall quality of a lighting system. These must be considered in the lighting design.

# Lighting level and maintained illuminance

Good vision requires sufficient brightness. Standards prescribe minimum requirements for lighting in indoor and outdoor areas and stipulate maintained illuminance values.

The lighting level has a great influence on how quick, safe and easy it is for the eyes to perform a visual task – for example when working at the computer or driving. Decisive factors here are the illuminance, luminance and reflective properties of the illuminated surfaces. Cylindrical illuminance is used as a measure of the impression of brightness which is largely dictated by the vertical illuminance levels. It is used above all to evaluate the ability to recognize faces.

important photometric planning value. It influences the number and characteristics of the lamps and light sources which are used – and therefore also the lighting energy consumption. Illuminance is a relevant planning quantity both for indoor and outdoor spaces.

The only exception: luminance  $L$  is used to evaluate roads with a speed limit above 30 km/h – for example major roads or tunnels.

When planning it should be taken into account that dark surfaces “swallow up” more light than light ones. Therefore: the lower the reflectance, the more difficult it is to perform a given visual task, and the higher the illuminance must be. Examples of reflectance:

This is because of the standardized reflection properties of the road surfaces, as well as the defined observer location: motorists see the light reflected in their direction from the “viewed road surface” – the luminance of which is determined by the material and direction and is measured in candelas per square metre ( $\text{cd}/\text{m}^2$ ).

- white walls up to 85 per cent
- light-coloured wood panelling up to 50 per cent
- red bricks up to 25 per cent

## Maintained illuminance

The illuminance dims over the years because luminaires, light sources and rooms age and attract dirt. For this reason, main-

## Illuminance and luminance

Illuminance, measured in lux ( $\text{lx}$ ), is the most

[23] Recommended reflectance  $r$  of walls, floors, ceilings and work areas according to DIN EN 12464-1.

[24] The luminance levels are critical for road lighting: motorists perceive the light reflected by the road surface as luminance.

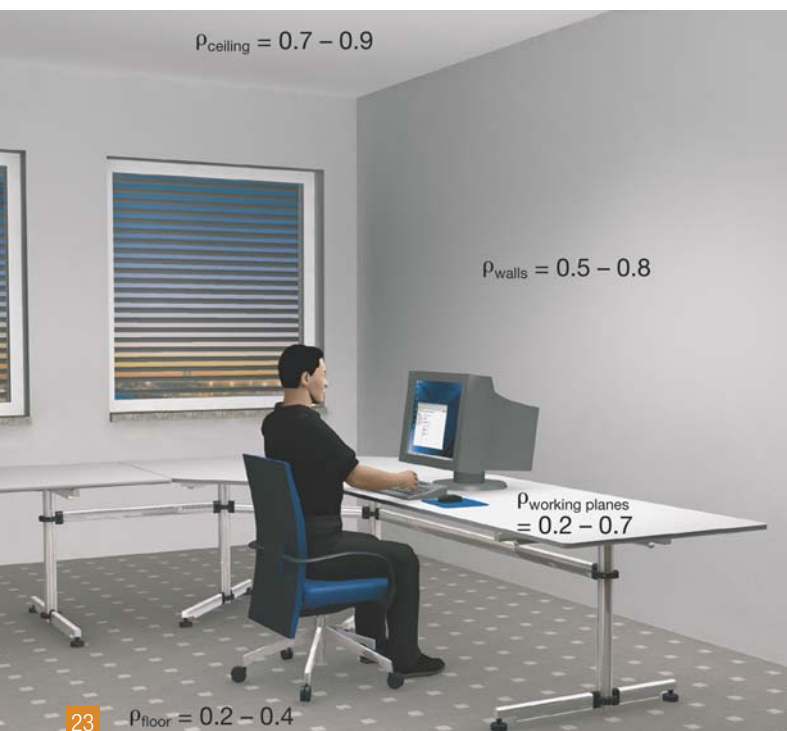

tained illuminance values are defined and illuminance levels are recommended in the relevant standards for lighting systems depending on the room type, task and activity. This maintained illuminance value ( $\bar{E}_m$ ) indicates the value below which the average illuminance is not allowed to fall at any time, regardless of the age and condition of the lighting system. This ensures that the minimum illuminance values are maintained for all visual tasks even after years of operation. The maintenance plan which the lighting designers are required to draw up defines the time of maintenance.

To compensate for the eventual decrease in illuminance, the new systems are specified with higher illuminance values (= illuminance on installation). The decrease is built into the planning in the form of the maintenance factor: Maintained illuminance = maintenance factor x illuminance on installation.

### Maintenance factor

The maintenance factor can be deter-

mined for each individual set of circumstances. It depends on the types of lamp and luminaire, the levels of dust and dirt in the space or the environment as well as the maintenance programme and schedule. Often the operational impact on the decline in illuminance is not sufficiently known at the time of planning the lighting. In such cases a maintenance interval of three years is given a maintenance factor of 0.67 (in clean rooms) or up to 0.5 (in rooms subject to high levels of dirt).

The maintenance programme – the intervals for cleaning and changing the light sources and maintenance of the system – shall be documented.

### Calculation plane

The surface where the illuminance is to be realized is generally taken as the calculation plane. Recommended heights for office work places: 0.75 m, for circulation areas maximum 0,1 m above the ground.

The illuminance is simple to measure and fairly straightforward to compute. Determining the luminance levels for street lighting entails more complex planning and measurement. It is based on the luminous flux of the light sources used, on the distribution of the luminous intensity of the luminaires, on the geometry of the lighting system and the reflectance properties of the road surface.

[25] The maintained illuminance value indicates the value below which the average illuminance is not allowed to fall during the operating life of a lighting system. In the example, the maintenance interval is three years.

## Standards stipulate maintained illuminance values

The quality characteristics of lighting, as well as the required maintained illuminance values of lighting for various visual tasks or activities are listed in the relevant standards. Key among these are DIN EN 12464-1 for indoor work places and EN 12464-2 for outdoor work places. Examples of maintained illuminance values in indoor rooms:

Office	500 lx
Operative field	bis 100,000 lx
Circulation areas	100 lx

Quality characteristics of street lighting are given in DIN EN 13201-2.

Recommendations:

Service road	7.5 lx
Main road	1.5 cd/m <sup>2</sup>
Car park	15 lx

## Maintained illuminance

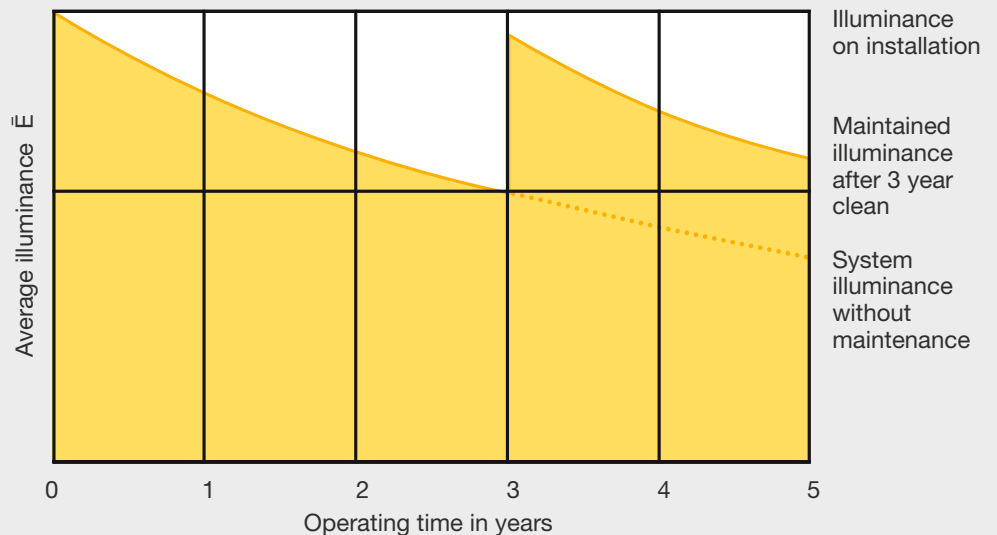



# Limiting direct glare

Glare is caused by (excessively) light surfaces within the field of vision. It can have a significant adverse effect on people's visual performance and well-being, and should therefore be limited.

Glare impairs visual conditions and causes fatigue and reduced concentration in the long term. It is important to limit glare in order to avoid errors and accidents in the work place and on the road.

Experts distinguish between two types of glare:

- **Disability glare** directly impairs vision, e.g. when looking into a spotlight.
- **Discomfort glare** is defined as perceived discomfort. Bright windows or lamps can have a highly irritating effect without the visual performance being directly impaired. However, discomfort glare creates an unpleasant sensation, especially when a longer period of time is spent in the space. The result? People tire quickly and their performance and feeling of general well-being decreases.

Disability glare of the kind encountered on roads, e.g. by oncoming vehicles, is seldom found in interior lighting. Here, discomfort glare is a factor. This is referred to as direct glare in DIN EN 12464-1 and limits are stipulated in the form of UGRs (Unified Glare Ratings).

- **Direct glare** is caused by luminaires themselves or by luminous surfaces.
- **Glare by reflection** is produced by reflections on shiny surfaces (see page 20f.).

Light sources are shielded by grids and special reflectors or covered by lenses and microprisms and thus provide glare protection; windows must be capable of being darkened.

## Glare evaluation using the UGR method

In interior lighting, psychological glare is assessed using the European standard DIN EN 12464-1 based on a glare formula: the unified glare rating (UGR). This takes into account all luminaires in the system which contribute to a sensation of glare. Modern planning programs can be used to calculate the UGR for specific locations in the space

and for different viewing angles. The UGR table, provided by luminaire manufacturers in catalogues or databases, is suitable for obtaining a rough assessment of whether a lighting system could cause glare.

The UGR method can also be applied even for LED lamps, as long as the individual LEDs are well shielded.

$$UGR = 8 \log \frac{0.25}{L_b} \sum \frac{L^2 \Omega}{p^2}$$

## The TI method for street lighting

Every motorist knows how dangerous glare can be in traffic. The effective limitation of physiological glare improves safety and is an important criterion of good outdoor lighting.

In street lighting, disability glare is evaluated using the TI (Threshold Increment) method. Glare evaluation is based on a specific viewing angle of the road user. The TI value indicates the percentage by which the visual threshold is raised as a result of glare. The visual threshold is the difference in luminance required for an object to be just perceptible against its background. DIN EN 13201 provides benchmark values.

The percentage increase in the TI threshold value is calculated using the following formula:

$$\frac{TI}{\%} = \frac{\Delta L_{BL} - \Delta L_0}{\Delta L_0} \cdot 100$$

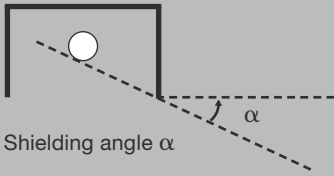

Shielding angle  $\alpha$

© licht.de

26

## Shielding and luminance

**Shielding [26]:** Excessively bright light sources in the field of vision can cause glare. Therefore lamps/light sources need to be appropriately shielded. For luminaires which are open at the bottom or have a transparent cover, the shielding angle is defined as the angle between the horizontal plane and the line of sight at which the luminous parts of the lamps are just visible in the luminaire.

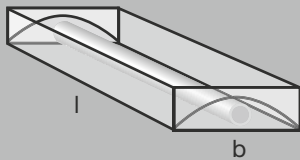

© licht.de

27



© licht.de

28

**Determining luminance [27+28]:** The average luminance of a luminaire is used to evaluate glare using the UGR method and is determined based on the light-emitting surface. It is calculated from the luminous intensity at angle ( $\gamma$ ) and the surface  $l \times w \times \cos\gamma$  visible from this angle  $\gamma$ . It is expressed in  $\text{cd}/\text{m}^2$ .

$$\text{Luminance: } \frac{l}{l \cdot b \cdot \cos\gamma}$$

[29] The UGR method takes into account all luminaires in the system which contribute to glare, accordingly also the brightness of the walls and ceilings. The outcome is a UGR index.

[30] To avoid glare from bright light sources, lamps should be shielded. The table gives the minimum shielding angle. The values do not apply to luminaires that are mounted below eye level, or to luminaires which emit light from their top half.



29

## Minimum shielding angle as per DIN EN 12464-1

Lamp luminance in $\text{cd}/\text{m}^2$	Minimum shielding angle $\alpha$
20,000 to < 50,000 e.g. fluorescent lamps (high output), compact fluorescent lamps	15°
50,000 to < 500,000 e.g. high-pressure discharge lamps, LEDs	20°
$\geq 500,000$ e.g. high-pressure discharge lamps, light bulbs with clear bulb, high power LEDs	30°

30

## Increasing the ambient luminance

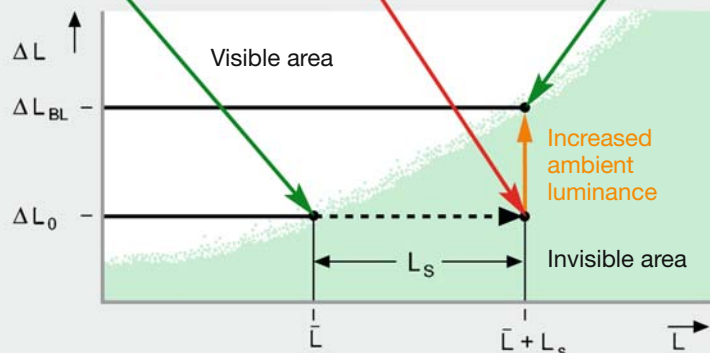

At night the eye adapts to the average road surface luminance ( $L$ ) with glare less street lighting. People or objects on the road can be seen if they are distinguishable from their surroundings by a luminance contrast of  $\Delta L_0$ . If sources of glare are added to this situation (e.g. oncoming cars) they produce diffuse

light and a kind of "veil" on the retina. The eye attempts to compensate for the glare i.e. the "veiling" luminance ( $L_s$ ) and adapts to a higher level of  $L + L_s$ . Objects can then no longer be perceived on the road. Increasing the ambient luminance from  $\Delta L_0$  to  $\Delta L_{BL}$  makes them become visible again.

31

© licht.de

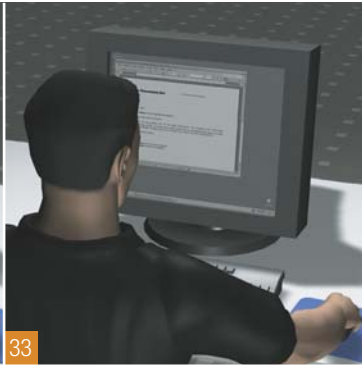

# Avoiding glare by reflection

Glare by reflection mainly affects contrast vision and results in similar disturbances to direct glare.

Unimpaired vision requires that contrasts – i.e. differences in luminance – are visible. For example, a text on a computer screen is only legible if there is a clear contrast between the letters and the background.

However light from luminaires or windows which is reflected by shiny surfaces reduces the contrast and, with increasing luminance levels, causes glare by reflection. The result? The eyes are put under great strain and tire quickly; concentration diminishes, headaches and dizziness may occur.

## Reducing glare

Glare by reflection can be avoided, or at least effectively reduced, by appropriate measures:

- Right selection and arrangement of light sources and luminaires.
- Correct arrangement of work places, so that light falls mainly from the sides onto the desk.
- Decoration of interiors preferably with light matt surfaces.

The contrast rendering factor (CRF) is used to assess the reflected glare on shiny horizontal surfaces (documents for reading and writing). This can be calculated using special software. For normal office work a

minimum CRF value of 0.7 is sufficient; a higher value is required when working with shiny materials.

## VDU workstations

The luminance values which can be mirrored in screens and cause reflections depend on the screens used. Modern screens with high background luminance and good antiglare properties permit significantly higher luminance limits.

According to DIN EN 12464-1, VDU workstation lighting must be planned so that all visual tasks can be performed at the workstation. Modern screens with a luminance of  $L \geq 200 \text{ cd/m}^2$  can also withstand relatively high luminance levels of up to  $3,000 \text{ cd/m}^2$ . But planners should select types and arrangements of luminaires that prevent irritating reflections.

The limit value luminance in the most commonly used screen settings is  $1500 \text{ cd/m}^2$  above an emission angle  $\gamma$  of  $65^\circ$ . However, screens with glossy surfaces are critical because even a white shirt will be reflected in them. They should not be used in offices. Furthermore: offices containing VDU workstations should have adjustable glare protection at the windows.

[32 + 33] Glare by reflection on the screen caused by unshielded luminaires, sunlight or reflections impairs visual performance and should be avoided.

[34 + 35] Glare by reflection also affects the readability of books and documents. Factors which make a significant contribution to reducing reflections include luminaires which emit both direct and indirect light, their proper positioning in the room, good antiglare protection and the correct arrangement of work places.

[36] Modern screens tolerate significantly higher luminance than their predecessors. DIN EN 12464-1 describes the acceptable limits for avoiding glare by reflection.

[37] For screens with a background luminance of  $L \leq 200 \text{ cd/m}^2$  (typical in offices with normal daylight levels and conventional flat screens), luminaire luminance levels of to  $1,500 \text{ cd/m}^2$  are allowed.

[38] For screens with a background luminance of  $L > 200 \text{ cd/m}^2$  (typical in offices with normal daylight levels and conventional flat screens), luminaire luminance levels of to  $3,000 \text{ cd/m}^2$  are allowed.



# Harmonious distribution of brightness

Excessive brightness differences are visually tiring and reduce the sense of well-being because the eyes are constantly required to adapt. But just as unpleasant as excessive contrasts are negligible differences in luminance which can quickly make a room appear monotonous.

The best solution is a harmoniously balanced distribution of brightness in which the luminance (symbol: L) of visual objects allows them to be clearly distinguished and differentiated against their background.

With regard to safety, DIN EN 13201 requires uniform illumination of the road surfaces of thoroughfares and the avoidance of dark zones. Major differences in brightness should also be avoided indoors; this allows any hazards to be spotted in good time, e.g. in industrial facilities. Accordingly the European standard DIN EN 12464-1 also recommends a balanced distribution of luminance levels which significantly aids visual performance and visual comfort in indoor work places.

Recommended reflectance levels according to DIN EN 12464-1 (see also fig. 23, page 16):

- Ceiling: 0.7 to 0.9
- Walls: 0.5 to 0.8
- Floor: 0.2 to 0.4

It should also be ensured that the luminance ratio between the work area and the immediate surroundings does not exceed 3:1. The luminance ratio between the work area and more distant areas should not exceed 10:1.

In offices, for example, lighting which is coordinated with the colours and surfaces of the interior helps ensure harmonious brightness distribution. Key criteria here include:

- Dedicated lighting for a particular work place or room
- Uniform illuminance on a surface (=  $U_0$  as the ratio of minimum to average illuminance), as required by DIN EN 12464-1.

[39] The illuminance in a space reveals nothing about the harmonious distribution of brightness. This is only apparent from the luminance values ( $\text{cd}/\text{m}^2$ ) as shown in this example.

[40] Roads, too, should be uniformly and thus “safely” lit. This is not necessarily “monotonous”.

### Balanced luminance levels

In order to achieve this, the luminance levels of all surfaces must be considered. These are determined by the reflectance and the illuminance of the surfaces.

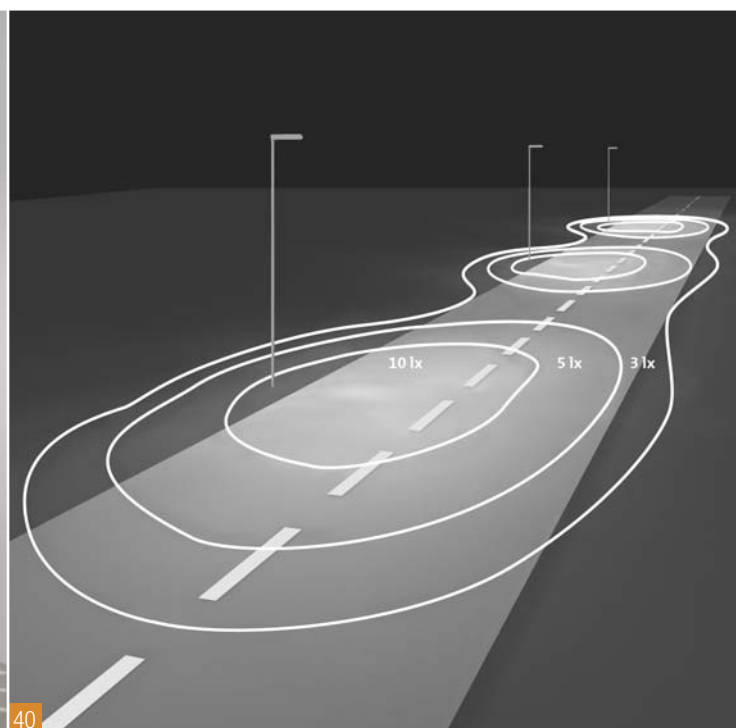

This can be improved through indirect lighting components.

- Light walls with good reflectance levels.

In high visual communication spaces DIN EN 12464-1 recommends illuminating

- walls with at least 75 lux and
- ceilings with at least 50 lux.

Higher illuminance levels are better in both cases, as they increase the visual comfort.

[41] A good street lighting provides security and a pleasant mood.

[42 – 47] Indoors, harmonious distribution of brightness is important for visual comfort. On roads, safety is improved by good longitudinal uniformity – which corresponds to harmonious brightness distribution.



41



42



43



44

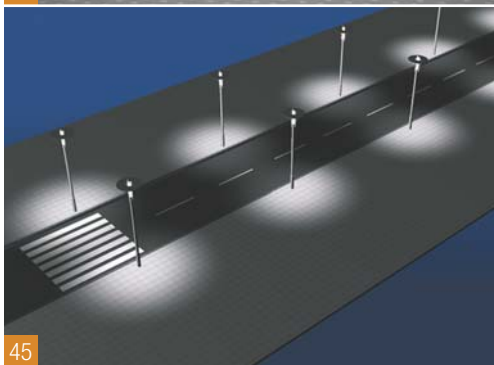

45

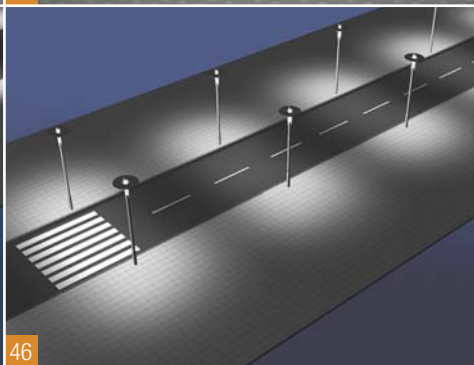

46

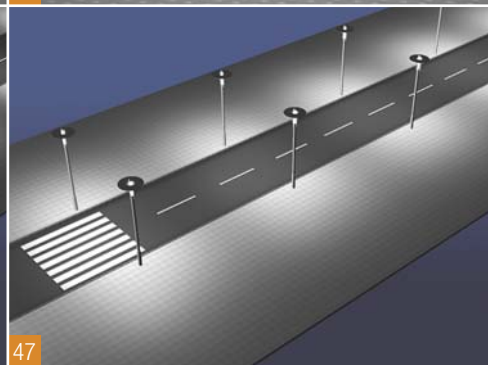

47



48

## Direction of light and modelling

Without light we cannot make out objects; without shadows we see objects merely as two-dimensional images. Only the right distribution of light and shade ensures that faces and gestures, surfaces and structures can be accurately discerned.

[48] Directional light and the correct distribution of light and shade reveal the details of the figures.

[49 + 50] Distracting shadows should be avoided if the light comes mainly from above left (for right-handed people – or from above right for left-handed people).

[51] In order to avoid stark shadows in sports halls, the lights are arranged so that their beams cancel out each other's shadows.

A pleasant light climate is created when the people, architecture and interior furnishings are illuminated in such a way that shapes and surface structures are clearly visible: distances can then be easily estimated, facilitating orientation within the room.

A mixture of diffuse light (such as indirect light on walls and ceilings) and directional light (such as direct luminaires or downlights) achieves optimum visual results and contributes to a pleasant visual climate.

Conversely, a bright room with nothing but diffuse lighting and no shadows leaves a monotonous impression: the lack of orientation makes us feel uncomfortable. By contrast, point sources of extremely directional light create strong shadows with stark edges. It is almost impossible to see anything in these stark shadows. They can give rise to optical illusions which often constitute a source of danger, for example when using tools or machines. The same applies for unsuitable stair lighting.

### Visual communication

A precondition for good visual communication is for objects and faces to be recognized quickly and easily. In rooms in which people move and work, DIN EN 12464-1 therefore stipulates an average cylindrical illuminance  $\bar{E}_z$  of at least 50 lux. In areas where good visual communication is especially important, such as in reception areas, shops and schools or in conference rooms, 150 lux are recommended as an average.

DIN EN 12464-1 cites modelling as an important quality criterion for the 3D perception of people and objects. It describes the relationship between cylindrical and horizontal illuminance at a particular point and should be between 0.30 and 0.60.

### Light direction

Directional light can emphasize visual details. However, stark and intrusive shadows (such as those caused by point sources of light) should be avoided. The light direction





is determined mostly by natural light falling from a certain angle into the room through a window. Stark shadows, such as those cast by a writing hand, can be compensated by artificial lighting.

In offices where desk arrangements are based on incident daylight, it is advisable to control the daylight by means of window blinds and to use continuous rows of luminaires on separate switching circuits to brighten distracting shadows. Where luminaires are arranged parallel to the window wall, the rear row of luminaires can lighten any stark shadows that might occur during the day.

In fast ball sports such as tennis or squash it is important to ensure sufficient shadows which allow players to perceive and gauge the trajectory and speed of the ball in an instant.







52

**warm white (ww)**  
2,700 – 3,300 Kelvin

**neutral white (nw)**  
3,300 – 5,300 Kelvin

**daylight white (dw)**  
über 5,300 Kelvin

◀ cosy light

functional light ▶

## Light colour – From warm to cool

We experience our environment not only through light and shadow, but also through colour. The light colour of a lamp also determines the spatial impression and is an important criterion in the planning of biologically effective lighting.

The light of each light source has its own so-called light (or luminous) colour. It is described by its colour temperature, measured in Kelvins (K). The higher the temperature value, the cooler white the light colour. The Kelvin temperature scale starts at absolute zero (0 Kelvin = -273.15° C).

### Determining colour temperature

Heating up the tungsten filament of an incandescent light bulb (for example) lights it up red initially, then yellow and finally white. The physicist Max Planck developed a mathematical formula for this kind of “temperature” radiation. It can also be used to describe light colours above the melting temperature of tungsten.

In order to determine the colour temperature, the colour impression of a lamp is compared in the human eye to that of a standardized “black body”, the light colour of which is determined by its temperature.

When such a black body is heated, it passes through graduations of colour from red, orange, yellow and white through to light blue. To represent clearly the perceptible colour space, the international lighting commission CIE developed a two-dimensional chromaticity diagram. This coordinate system contains all spectral colours on a horseshoe-shaped curve: the black-body curve of all colour temperatures of white light. In the centre is the white point W (= no colour). Here, all colours are present to an equal amount ( $x = 0.33 / y = 0.33$ ).

The colour of a light source is indicated on or right next to its CIE spectrum locus in the colour table depending on its colour temperature. This temperature is identified by the closest colour temperature ( $T_{cp}$ ). This is the temperature that heated platinum requires to take on the same colour as the light source. Therefore low colour temperatures of up to approximately

[52] The light colour of the lamp used determines the impression of the room: from homely/warm white through to functional daylight white.

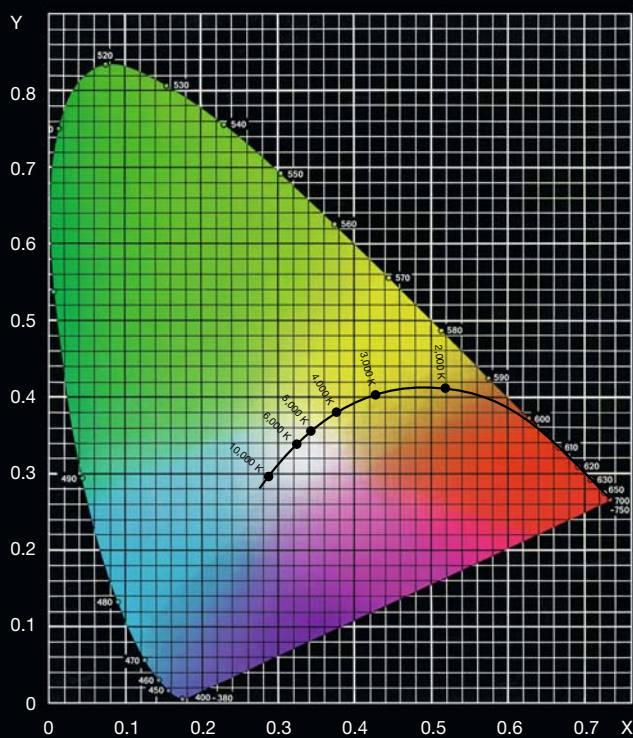

53

3,300 Kelvins describe warm, yellow-red-dish light colours and high colour temperatures describe cool, light blue and white colour temperatures – similar to daylight which reaches around 6500 kelvins even on a cloudy day.

The light of lamps of the same light colour can have a completely different spectral composition and therefore different colour rendering, too. It is not possible to draw conclusions from the light colour of a lamp about the quality of its colour rendering.

### LEDs – binning for good quality

The production of LED chips requires special attention in terms of light colour. Fluctuations occur in the light colour within batches during industrial production, and so LEDs are measured after production and sorted into different tolerance class bins. Only the use of carefully selected binning groups guarantees uniform brightness levels and light colours – and is thus an important quality feature.

A standard ANSI (= American National Standards Institute) binning structure was created in 2008. Colour deviations can be determined with even greater precision using MacAdam ellipses (also known as

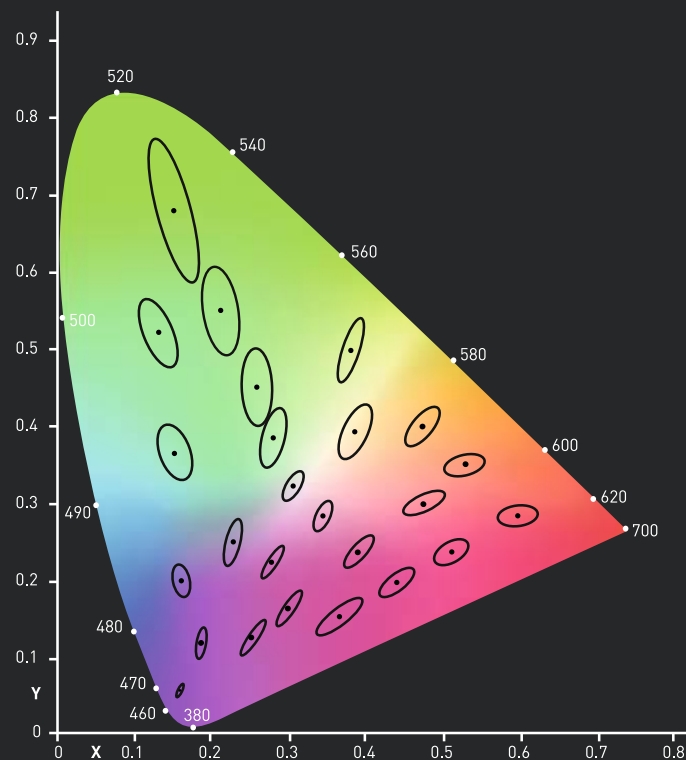

54

SDCM, standard deviation of colour matching). These describe areas in the CIE chromaticity diagram in which the human eye perceives no difference from the centre of the ellipse. MacAdam ellipses are often enlarged to a diameter which is three, five or seven times larger. These MacAdam ellipse steps provide users with information about colour differences. The smaller the colour distances, the better: light sources with a 3-step MacAdam ellipse colour distance are more similar than two light sources with a 7-step MacAdam ellipse colour distance.

### Light colour also has a non-visual effect

The light colour also influences people's circadian rhythm. It is therefore an important criterion in the planning of biologically effective lighting based on natural daylight.

Daylight white light with a high blue proportion of at least 5,300 Kelvins (K) is especially biologically effective in terms of daytime stimulation. Suitable light sources here include fluorescent lamps with an appropriate blue component. White LEDs with colour temperatures between 6,000 and 8,000 K which are located in the low-wavelength, bluish spectrum are characterized by their high biological impact.

Stimulating lighting only makes sense during the day; in the evenings warm light colours of up to 3,300 K in combination with low illuminance levels are recommended. DIN SPEC 67600 provides planning information.

 *The ZVEI guide "Reliable Planning with LED Lighting" provides further information about LEDs; licht.wissen 19 contains information on "biologically effective lighting".*

[53] The chromaticity diagram of the international lighting commission CIE with the standardized "black body curve", showing the light colours of heated platinum (in Kelvins, K). The colour of light sources is then identified by the closest colour temperature.

[54] The light colour of LED chips is subject to natural fluctuations. Colour deviations are described by means of MacAdam ellipses in the CIE chromaticity diagram.





55

### Colour rendering quality of light sources

R <sub>a</sub> range	Quality	Typical light sources
90 and above	Exzellent	LEDs, colour-optimized fluorescent "De-luxe" lamps, colour-optimized halogen metal halide lamps, incandescent lamps
80 – 89	Very good	Three-band fluorescent lamps, Efficient metal halide lamps
70 – 79	Fair	Standard fluorescent lamps
60 – 69	Satisfactory	Standard fluorescent (bright white) lamps, halogen metal halide lamps
40 – 59	Poor	Standard fluorescent (warm tones), high-pressure mercury vapour lamps
20 – 39		High-pressure sodium vapour lamps
below 20	No colour vision	Low-pressure sodium vapour lamps (not allowed in work places)

### Colour coding of light sources

1 <sup>st</sup> digit = Colour rendering/ R <sub>a</sub> range		2 <sup>nd</sup> + 3 <sup>rd</sup> digit = Light colour/ Colour temperature	
9	90 – 100	27	2,700 K
8	80 – 89	30	3,000 K
7	70 – 79	40	4,000 K
6	60 – 69	50	5,000 K
5	50 – 59	60	6,000 K
4	40 – 49	65	6,500 K



56

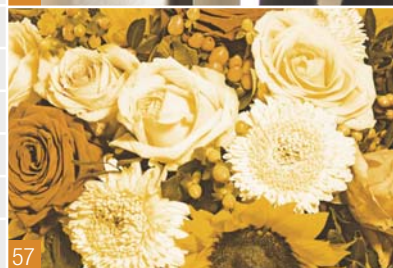

57



58

# Colour rendering

Light and colour determine the “climate” of a room. For our own sense of well-being, it is important that the colours of the world around us, and especially human skin, are rendered as realistically as possible.

If a co-worker’s skin colour appears dull and colourless in the office lighting, the problem is not the cool light colour of the lamp, rather its poor colour rendering capacity. This light source property describes how “natural” illuminated faces or objects appear in its light.

Good colour rendering is an important quality feature of artificial lighting – and crucial in certain areas such as restaurants, or in the assessment of colour samples. The impression of colour is determined by the interaction between the colour of the observed objects (= their spectral reflectance levels) and the spectral composition of the light. That is why we always perceive objects in daylight as “natural”. This is not surprising

because the sun combines all spectral colours in its spectrum. However, if an object is illuminated with a dominant colour, for example blue, it will appear dull, cool and often in a distorted colour.

## Everyday experience

In going about their lives people are familiar with a range of body colours which may appear differently depending on the lighting, but for which certain “visual benchmarks” exist. The colour of human skin in daylight is stored in people’s subconscious.

If a particular spectral colour is missing in artificial light, or if certain spectral colours are overemphasized in the lamp’s spectrum, the skin colour will appear in a somewhat different colour but still be regarded as ‘natural’ due to people’s real-world knowledge. However, there can be considerable deviations in the case of coloured materials for which we have no “prior knowledge” or if certain spectral colours in a lamp’s light are greatly overemphasized.

## Colour rendering index $R_a$

The general colour rendering index  $R_a$  was developed to describe the qualities of colour reproduction (colour rendering index, CRI). The best  $R_a$  value is 100: this renders all colours naturally. The lower the  $R_a$  value, the worse the colours of the illuminated object are rendered.

Colour rendering properties are evaluated using the so-called colour test method. This is based on 14 predominant test colours, each of which is observed under a reference light source ( $R_a$  100) and the light source being tested. The reference for assessing the rendering properties

- of daylight white light sources is natural daylight with a colour temperature of around 6,500 kelvins (K); this is equivalent to a cloud-covered sky with no direct sunlight.
- of lamps with a colour temperature < 5,000 K is black body light.

The differences in the colour appearance are evaluated based on a mathematical formula. The smaller or larger the deviation of the colour rendering, the better/worse the colour rendering property of the light source being tested.

Indoors – and in particular in work places – only light sources with an index of at least  $R_a$  80 should be used. All light sources designed for residential and office lighting ensure this today. Optimum  $R_a$  100 ratings are obtained by halogen lamps; however these are not very efficient. LEDs, on the other hand, are highly energy efficient, durable and at the same time very close to the ideal: depending on the type and quality, LEDs today can achieve values of up to  $R_a$  98 – higher than those offered by fluorescent or energy-saving lamps. At the lower end of the  $R_a$  scale is the low-pressure sodium vapour lamp. It emits light only in one spectral colour which, accordingly, precludes accurate colour vision. Thanks to its superior efficiency of up to 200 lm/W it is nevertheless often used in situations in which colour fidelity is not required, such as in lighting on infrequently used roads.

An internationally recognized colour designation for light colour and colour rendering provides orientation when lamps are replaced or the light atmosphere in a room is to be selectively altered. Three digits give information on the respective light source. For example, 840 denotes a fluorescent lamp with a colour rendering index of 80 to 89 and a colour temperature of 4,000 K (= neutral white).

[55] In situations in which it is important to be able to assess people and colours, the colour rendering quality of the lighting should be as high as possible. A rating of at least  $R_a$  80 is recommended for indoors.

[56] Does this colour suit me? Good colour rendering is also important when trying on and choosing clothes.

[57 + 58] Lamps may have different colour rendering properties despite having the same light colour. For example, if there is too little red in a lamp’s spectrum (left), red object colours will only be rendered incompletely or not at all.



# Light generation in the 21<sup>st</sup> century

LEDs have revolutionized lighting in recent years. New and efficient technologies are increasingly replacing the old thermal radiators.

The relative importance of different types of light generation has shifted dramatically in recent years: incandescent light bulbs, even in the form of halogen lamps, are on the decline. Fluorescent lamps and other gas discharge lamps are also increasingly being replaced by LED technology – in the form of retrofit lamps, modules or complete systems.

### Why the change?

The generation of artificial light requires energy: 15 percent of electric power worldwide is still used for lighting (IEA/UNEP, spring 2014). Which is why any efforts to reduce energy consumption always involves lighting savings. The photometric requirements for each application must nevertheless be met (such as minimum illuminance at work), as these are often safety-related, and thus also of legal significance.

Governments are applying great pressure in order to save light-related energy; the European Union (EU) has introduced directives aimed at increasing energy efficiency. Light sources that do not meet these requirements may no longer be marketed as new products in the EU. In addition, end users are informed by corresponding markings on the energy labels showing which light sources are highly efficient (A++ with green arrow = “desirable”) and which are particularly inefficient (E with red arrow = “Warning, not desirable”). Similar arrangements now also apply in other countries outside the EU.

### What does this change mean in practice?

Light sources and lamps based on less energy-efficient technologies are either no longer produced as a direct result of the directives or are losing their attraction to such an extent that they are no longer used – regardless of any other benefits they may have. Thus, manufacturers which previously worked mainly with traditional lighting

technology must effect a major change if they wish to remain successful in the market. However, efficiency is not everything: besides generating brightness, light also needs to meet other requirements (see “Quality characteristics of lighting”, page 15).

At the same time the applications are becoming increasingly complex, which is why there is now strong demand for professionals in the planning, implementation and operation of good lighting systems. This is giving rise to new opportunities because there is now an increased focus on controllability, and thus also the question of what “language” the components use to speak with one another; should DALI components be integrated into a bus system or is wireless control preferable?

Colour? Dimming? It is the user who decides how elaborate the system should be and how it is ultimately controlled: pre-programmed and then automatically controlled, or by APP, by switch or remote control.

### Light generation – traditional: Incandescent and halogen lamps

Incandescent and halogen lamps are thermal radiators in which light is generated by heating the tungsten filament wire. The glass bulb can be evacuated or filled with gas – generally with noble gas(es) or nitrogen. Incandescent lamps have low luminous efficacy, but they offer perfect colour rendering and are fully dimmable.

However, the luminous efficacy can be increased by means of double coiling and/or refinement of the gas filling, e.g. through the addition of krypton or xenon. Halogens reduce the evaporation of tungsten from the filament, thereby preventing bulb blackening in halogen lamps. Further efficiency gains can be obtained through the use of infrared (IR) reflective coatings of the glass bulb.

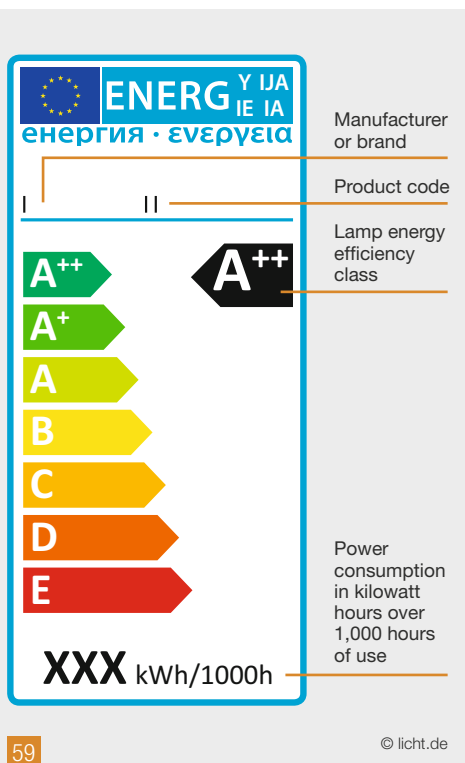

59

© licht.de

[59] The energy label for lamps (as of September 2013) provides information on the efficiency classes of light sources. LEDs and energy saving lamps are especially efficient.

[60] Efficient and elegant. The curved OLED ceiling lamp provides pleasant, glare-free light.



Following a European Commission resolution, halogen lamps in the classic light bulb shape (most of which are efficiency Class D) and E14 or E27 screw base will remain on the market until September 2018; there is no deadline for halogen lamps designed for G9 or R7 sockets that are used for example in desk lamps or ceiling lights.

### Discharge lamps

Discharge lamps generate radiation from an arc between two electrodes; this is emitted either directly as visible light from the lamp filling itself or is converted from UV-radiation into visible light by luminescent materials on the inside of the tube.

The luminous flux decreases over the useful life of the bulb. In combination with expired lamps this results in a decline in the level of luminous flux from the system which is not allowed to fall below a certain minimum value (80%). At this point the lamp has reached the end of its economic or service life.

For their operation discharge lamps require

- ballasts which limit the current flowing through the lamp, and
- starter elements for ignition.

### Ballast always needed

Electronic ballasts are recommended for fluorescent lamps and high-pressure (intensity) discharge lamps of lower wattages because they ensure smooth and efficient

lamp operation. Depending on their design they may also offer further advantages:

- Instant start and flicker-free ignition
- Flicker-free light through high-frequency operation
- Automatic shutdown of defective lamps
- Control and dimming as required.

UV-absorbing tubes generally also reduce the UV radiation produced by discharge lamps. High-pressure discharge lamps should always be operated in enclosed luminaires unless they are specifically approved for open designs.

### Fluorescent lamps and induction lamps

Fluorescent lamps are low-pressure discharge lamps. The chemical composition of the luminescent material with three or five highly prominent spectral ranges (in the blue, green and red sectors) determine, among other things, the light colour and colour rendering. Fluorescent lamps have a

- long life and
- high luminous efficacy,

however the level of the luminous flux depends on the ambient temperature. Depending on the lamp type, the temperature for peak light output is given as 5° C, 25° C or 35° C. Large deviations from these values substantially reduce the luminous flux (e.g. to below 20% at -20° C).

“High efficiency” fluorescent lamps with a 16 mm tube diameter are particularly eco-

nomical. “High luminous flux” lamps, by contrast, are ideally suited for applications in rooms with high ceilings. NB: T16 fluorescent lamps only display their specified technical characteristics and given service life when operated using electronic ballasts.

### High-pressure discharge lamps

The main high-pressure discharge lamps include metal halide lamps and sodium vapour lamps – double-socketed and in tubular or ellipsoid form, depending on the type.

Sodium vapour lamps are particularly energy efficient, since they are characterized by their very high luminous flux. However, their yellow light is primarily used in road lighting due to the poor colour rendering ( $R_a \leq 60$ ).

Metal halide lamps provide white light, good colour rendering and high luminous efficacy through the addition of halogen compounds of different metals in the filling of the lamp. The type of additive determines the light colour (from warm white (ww) and neutral white (nw) through to daylight white (dw)) and the colour rendering properties. The light of these lamp types can readily be directed, which is why they are especially suitable for large-area lighting, industrial lighting and the illumination of sports grounds.

**Light generation today: LEDs**

Light generation in tiny electronic components or in surfaces with eco-friendly materials: controllable, durable and efficient. Today's LEDs are suitable for almost every lighting task.

The LED is an electronic semiconductor element that emits light when current passes through it. The solid crystal is stimulated to radiate light by means of direct current: the electronic chip emits light as the result of compensation between an excess of electrons at the junction between the n-type semiconductor region and the p-type semiconductor with its lack of electrons. Depending on the material of the semiconductor crystal, monochromatic light is produced in a narrow waveband.

White LED light can be generated using different methods. The most common method is "luminescence conversion" which is also used in fluorescent lamps. Here, a thin layer of fluorescent phosphorus is evaporated above a blue LED chip. Some of the blue light is converted into white light by the yellow phosphorus. Another way of obtain-

ing white LED light is to mix coloured light: RGB colour mixing. This additive colour mixing of red, green and blue (= RGB) can produce white light in addition to all other light colours.

In practice, almost all colour temperatures – from 2,700 to 7,000 kelvins – and very good colour rendering values of  $R_a > 90$  can be achieved. If a uniform light colour is important in all LEDs for the user, strict binning (see page 26f.) is essential.

There are three basic LED construction types:

- Wired (radial) LEDs represent one of the earliest forms of LED. They are often used as simple signal indicators due to their low luminosity; they play no role in lighting.
- SMD (= surface-mounted device) LEDs are glued directly onto a printed circuit board and contacted in a solder bath. The LED chip sits on a housing or wafer with contacts.
- COB (= chip on board) LEDs are used for very powerful, tightly packed LED modules; the LED chip is mounted directly on the board.

The chips are mostly offered as pre-mounted modules on circuit boards. Complemented with a power supply unit, an outer bulb and e.g. an E27 base, the LED lamp can be used directly in the form of a retrofit. There are now many LED luminaires on the market, offered as complete systems including non-replaceable LED modules.

Ever higher luminous efficacy claims of more than 200 lm/W are regularly published. These are, however, lab values which cannot be obtained in practical operation due to electrical, optical and especially thermal losses. The service life is also significantly influenced by environmental factors: only good thermal management (i.e. good heat dissipation) can ensure high values.

**Innovative: OLEDs**

The glass pane of a window which lets in daylight in the middle of the day and acts as a light source at night might sound rather futuristic at present, yet the first OLED-based luminaires are already on the market. The extremely thin panels, the shape of which can be flexibly adapted to



61



63



62



64

[61] The lamp jackets of the first incandescent lamps were evacuated, i.e. the tungsten wire of the coil glowed in a vacuum; migrating tungsten molecules blackened the glass bulb. In modern halogen lamps, noble gases limit the freedom of movement of the tungsten molecules. Thermal radiators are relatively inefficient; conventional incandescent light bulbs have already been withdrawn from the market in Europe.

[62] In 230V and low voltage halogen lamps, the halogen cycle yields higher luminous efficacy and longer life.

[63] Fluorescent lamps are low-pressure discharge lamps and work with low-pressure mercury vapour. The composition of the luminescent material on the tube wall can be used to alter the light colour and colour rendering of fluorescent lamps.

[64] High-pressure discharge lamps contain a burner in which the light is produced by electrical discharge in gases or metal vapours, or a mixture of both. The metal-halide lamp shown has a burner made of transparent ceramic which ensures consistent colour quality.

any surface, saves both space and energy. Organic LEDs are now opening up new dimensions in display technology and (large-area) lighting. Their special appeal also lies in their environmental friendliness: they contain no mercury or other toxins, and can be recycled.

In OLEDs, the current flows through ultra-fine layers of small molecules (smOLEDs) or long-chain polymers (pOLEDs). Their structure is reminiscent of a sandwich, embedded between two large electrodes. When voltage is applied, electrons and “holes” (positive charge carriers) drift to the middle and recombine there, similar to the balancing which takes place at the p-n junction in LEDs.

The material used in OLEDs also determines the colour of the light. However, the colour can change, both on the entire surface and at specific points. This property is used in OLED screens, which are already in use today. However, the luminous efficacy of organic light-emitting diodes is relatively low – values of only up to 65 lm/W have been achieved to date.

And the service life is still “only” 10,000 hours. The great challenge here is the sensitivity of the ultra-thin films to oxygen and water. Suitable plastic materials must be used to protect the sensitive organic layers throughout their lifetime.

Innovative light sources continue to be developed. Examples here include laser headlights in the automotive industry and quantum dots – tiny nanocrystals which are already used in LCD screens.

 Further information on LEDs is available in *licht.wissen 17 “LED: The Light of the Future”*. *licht.wissen 20 “Sustainable Cities”* contains information about sustainability in lighting.

## Light sources: Efficiency and colour rendering

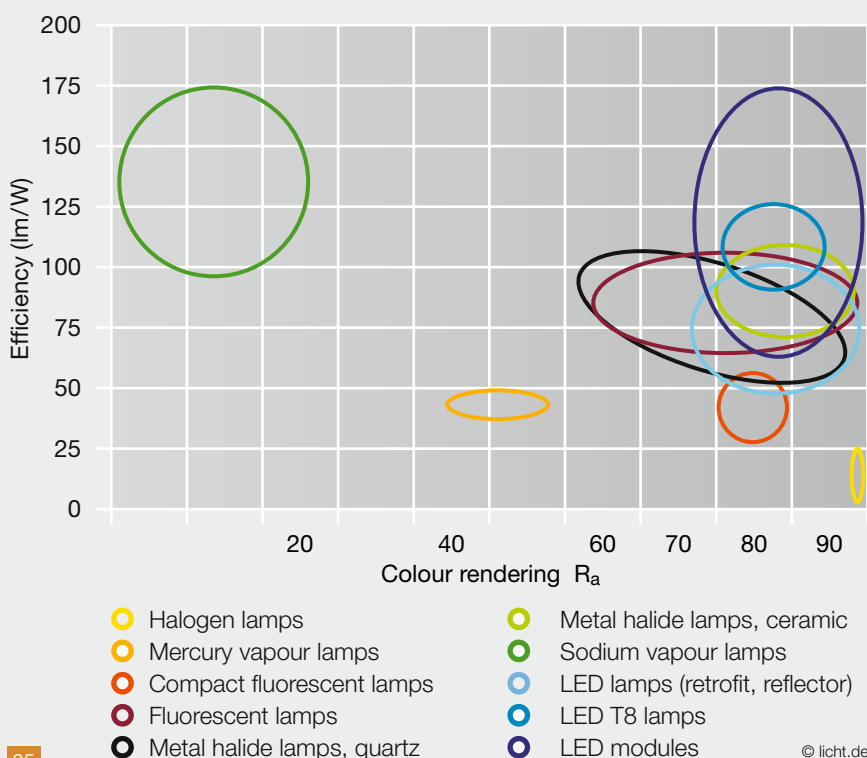

## How LEDs work

LEDs are electronic semiconductor components. They emit points of light, the colour of which is determined by the semiconductor material. The LED chip is moulded in a plastic housing to protect it from environmental influences and to provide the electrical contact; lenses direct the light.

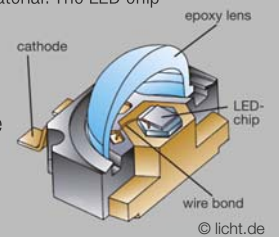

66

## How OLEDs work

OLEDs consist of extremely thin organic layers, sandwiched between large electrodes. When current flows through them, visible radiation is created. OLEDs are sensitive to oxygen and water, and are therefore encapsulated.

“Getter” material provides protection against moisture.

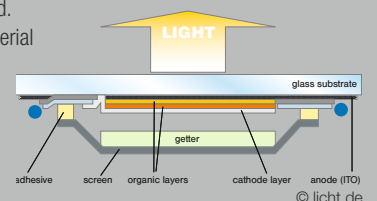

67

65





68

No.	Lamp/module type	Lamp/ module output (Power rating, watts)	Luminous flux (lumens, lm)	Luminous efficacy (lumens/watts)	Light colour
<b>Linear fluorescent lamps</b>					
1	Fluorescent lamp Ø 26 mm	18 – 70	870 – 6,200	61 – 89	ww, nw, dw
2	Fluorescent lamp Ø 16 mm	14 – 80	1,100 – 6,150	67 – 104	ww, nw, dw
<b>Compact fluorescent lamps</b>					
3	2-tube lamp, elongated design	16 – 80	950 – 6,500	67 – 100	ww, nw, dw
4	1, 2 or 3-tube lamp, compact design	10 – 42	600 – 3,200	60 – 75	ww, nw, dw
5	Tube lamp with integrated electronic ballast	8 – 30	380 – 2,000	48 – 66	ww
<b>Metal halide lamps</b>					
6	With base at one end, ceramic	20 – 400	1,600 – 41,000	80 – 108	ww, nw
7	With base at one end, ceramic	20 – 35	1,650 – 3,000	75 – 79	ww
8	With base at both ends, ceramic	70 – 150	5,100 – 15,000	73 – 108	ww, nw
<b>Halogen lamps</b>					
9	Reflector form	10 – 100	100 – 1,200		ww
10	Bulb form	18 – 105	170 – 2,000	9 – 18	ww
<b>High-pressure sodium vapour lamps</b>					
11	Tube form	35 – 1,000	2,200 – 128,000	63 – 145	ww
<b>LED-lamps</b>					
12	Reflector form, mains voltage	3 – 8	200 – 575	42 – 86	ww, nw
13	Reflector form, low voltage	2.8 – 8.5	230 – 660	50 – 83	ww, nw
14	Bulb form	2 – 18	230 – 1,522	78 – 117	ww, nw, dw
15	LED filament lamp	2 – 8	230 – 806	78 – 134	ww
16	Tube form Ø 26 mm	8.7 – 27	1,100 – 3,700	124 – 126	ww, nw, dw
<b>LED-modules</b>					
17	Rigid LED module	size-based	size-based	80 – 150	ww, nw, dw
18	Flexible LED module	length-based	length-based to approx. 4.000 lm/m	80 – 120	ww, nw, dw
19	Standardized LED module (Zhaga)	7 – 50	1,100 – 5,000	100 – 150	ww, nw,
20	Standard LED module	7 – 50	1,100 – 5,000	100 – 150	ww, nw,

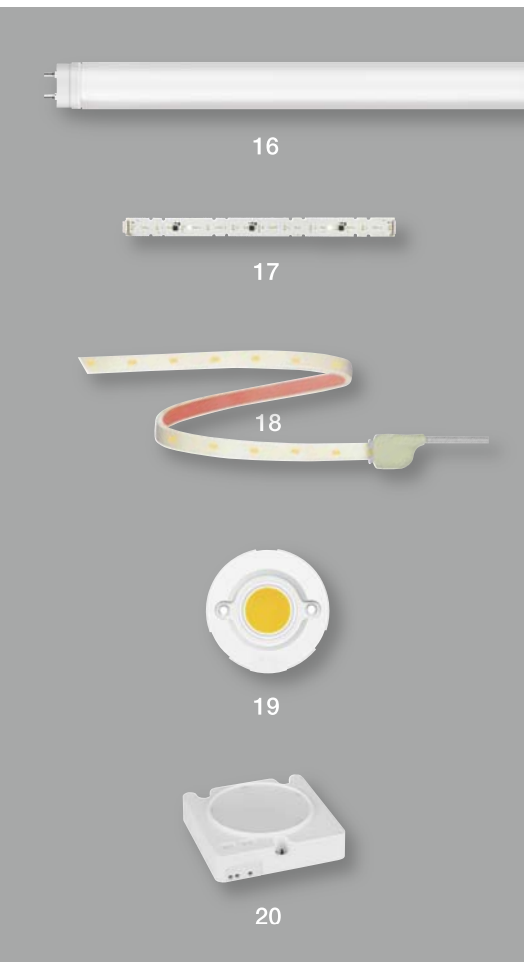

# Light sources

Selecting the right lamp is a precondition for good lighting. This page features the most important light sources with their technical specifications.

## Fluorescent lamps [1, 2]

Fluorescent lamps are characterized by their high luminous efficacy, good colour rendering and long life. Operation with an electronic ballast (EB) (essential for 16 mm diameter T5 lamps) improves the energy efficiency, light quality and service life. All fluorescent lamps can be dimmed with a suitable ballast.

## Compact fluorescent lamps [3 – 5]

The compact form of CFLs means that they can be integrated into smaller luminaires. Lamp types with built-in ballast are suitable for conventional screw sockets (5). CFLs are also available with excellent starting properties, improved switching frequencies and in very warm light colours.

## Metal halide lamps [6 – 8]

The principal advantages of metal halide lamps are their brilliant light, good colour rendering and excellent light control characteristics. Modern lamps with a ceramic burner – operated with an electronic ballast – have a luminous efficacy of up to 110 lm/W and are highly energy-efficient and dimmable. Metal halide lamps are ideal for industrial and stadium lighting.

## Low-voltage halogen lamps [9]

Low-voltage halogen lamps also impressively combine exceptionally brilliant light with perfect colour rendering. With appropriate transformers, they can be dimmed. Low voltage halogen lamps have to be operated with a transformer that reduces the voltage to 12 V.

## High-voltage halogen lamps [10]

High-voltage halogen lamps can be operated directly from the 230V mains supply. They provide a pleasantly fresh, brilliant light. High-voltage halogen lamps have very good colour rendering ( $R_a$  100) and

are fully dimmable. It will no longer be allowed to retail high-voltage halogen reflector lamps from 1.9.2016.

## High-pressure sodium vapour lamps [11]

High luminous efficacy and a long service life are the characteristics of sodium vapour discharge lamps, making them extremely economical options for outdoor lighting. They need appropriate ballasts and igniters for operation.

## LED lamps [12 – 16]

The development of LED lamps, also known as LED retrofits (LED ni = non-integrated), means that many of the advantages of LED technology can now be exploited in existing luminaires. Offering good colour rendering and different light colours, they represent durable and efficient replacements for conventional lamps. If they are used to replace fluorescent lamps, the light distribution is changed. Depending on the mounting (retrofit or conversion) the luminaires must be electrically converted. The electrical safety aspects should be checked by a professional.

## LED modules [17 – 20]

LED modules and LED light engines (= LED modules with ballast) deliver outstanding efficiency and reliability. Modules generally consist of LEDs mounted on a base, an optical system with wide-angle lenses and reflectors. They are electrically ready for connection. LED modules (LED si = semi-integrated / LED i = integrated) are versatile and virtually maintenance free, provide white and coloured light with good colour rendering, are dimmable and easy to control. Users generally encounter LED modules as fixed installations in lamps; otherwise, the installation should be performed by qualified personnel.

Colour rendering Index $R_a$ (in some cases as range)	base
85 – 98 85 – 93	G13 G5
80 – 93 80 – 90 80 – 90	2G11; 2G7 G23; G24; 2G7; GX24 E14; E27; B22d
80 – 85 85 – 90 75 – 95	G8,5; G12; G22; GU6,5; GU8,5; GY22 PGJ5 RX7s; RX7s-24
100 100	GU4; GU5,3; E14; E27; B22d
25	E27; E40
80 – 90 80 – 90 $\geq 80$ $\geq 80$ 70 – 85	GU10 GU5,3 E14; E27; GU5,3 E14; E27 G13
> 80 > 80 > 80 > 80	

ww = warm white, colour temperature up to 3,300 K  
 nw = neutral white, colour temperature 3,300 K to 5,300 K  
 dw = daylight white, colour temperature over 5,300 K

# Luminaires: Selection and light distribution

Luminaires differ not only by application and design, their lighting properties also need to be taken in consideration when making the selection.

Luminaires accept light sources and connect them to the power source. They divert and distribute the light from the lamps, should be easy to install and maintain – and match the interior design and the furnishings. Luminaires are selected on the basis of:

- the intended use (indoor or outdoor light),
- the type and number of light sources (such as LED module, low or high-pressure discharge lamp),
- the structural type (open or closed luminaire),
- the type of mounting (recessed, surface-mounted or pendant),
- the photometric properties (such as luminous flux distribution, luminous intensity distribution, luminance distribution and light output ratio),
- electrical properties including components required for lamp operation (e.g. electrical safety, protection class, RFI, ballasts, ignition and starter devices),
- mechanical properties (such as mechanical safety, degree of protection, fire safety features, impact resistance, material properties) and
- the design, construction and size.

## Luminous flux distribution

Total luminous flux  $\Phi_L$  consists of the light flows in the lower  $\Phi_U$  and the upper  $\Phi_O$  half of the luminaire. According to DIN 5040, luminaires are classified based on the proportion of luminous flux emitted in the lower half of the luminaire using letters A to E.

For most outdoor applications, luminaires for direct lighting are normally the preferred option. However, for decorative lighting in pedestrian precincts, parks etc., luminaires with a small indirect lighting component can be usefully employed to highlight trees or building façades.

## Luminous intensity distribution

The three-dimensional distribution of the luminous intensity of a luminaire is indi-

cated by the luminous intensity distribution model. It can be shown for various planes in polar diagrams (LDCs). The shape of an LDC shows whether the luminaire has a narrow or wide-angle, symmetrical or asymmetrical beam. Intensity distribution curves are usually established under standardized luminaire operating conditions using a goniophotometer. They provide the basis for planning interior and exterior lighting.

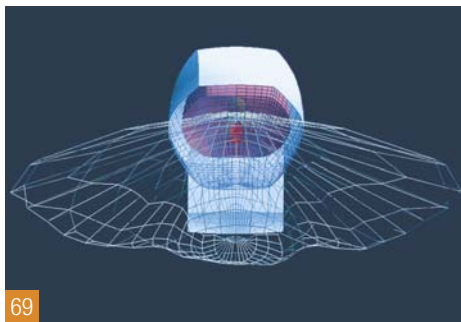

## Luminance distribution and shielding

To reduce the glare, luminaires shall not exceed a given cut-off angle. To assess the glare produced by luminaires, it is necessary to know their mean luminance at angles critical for glare (see page 19). The rating is made using the UGR (indoors) or the GR (outdoors) method.

## Luminous intensity: cd or cd/klm?

Luminous intensity distribution curves (LDCs) are specified as luminous intensities (cd). The unit cd/klm (= candela per kilolumen) is often used for this. In luminaires with conventional lamps, the luminous intensity is related to the luminous flux of the lamp. In LED luminaires (where  $\eta_{LB} = 1$ ) the luminous intensity refers to the luminous flux given for the luminaire.

## Light output ratio $\eta_{LB}$

How economical is a luminaire? In luminaires with conventional (replaceable) lamps, the light output ratio  $\eta_{LB}$  represents

a key quantity. It indicates how much of the lamp's luminous flux is actually emitted during operation of a luminaire. Depending on the luminaire design, the light output ratio of fluorescent and discharge lamps is between 60 and 90, sometimes even exceeding 100 percent as a result of the luminous flux of fluorescent lamps. The luminaire luminous flux is therefore the lamp luminous flux multiplied by the light output ratio.

It makes no sense to provide a separate luminaire light output ratio for LED luminaires with integrated LEDs. If the luminous flux of the luminaire is given as a parameter, a light output ratio of 100% is assumed ( $\eta_{LB} = 1$ ).

## Planning at 25° Celcius

Light output ratios are measured in the laboratory at an ambient temperature of exactly 25° C. Hence the need to plan a lighting installation on the basis of the luminous flux established for a lamp at 25° C.

Otherwise, the illuminance levels calculated for this lighting system will be incorrect.

[69] Light intensity distribution of an outdoor luminaire, measured using a computer program.

[71] An LED luminous ceiling with opal covering provides glare-free, indirect light which can be controlled to change the light levels at different times of the day.

[72] LED spotlights direct light precisely onto display areas and shelves.



## Light control

Optical phenomena are used to direct the light of a lamp in a certain direction, or distribute or filter it, especially

- Reflection
- Refraction



### Specular reflection

There is no light scatter on mirror surfaces such as mirror reflectors and grids made from highly polished anodized aluminium; this is called specular reflection. Precise luminous intensity distribution and luminance limitations are achieved through exact mirror forms.

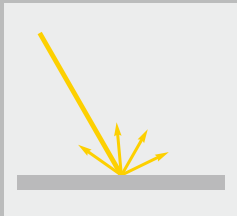

### Diffuse reflection

In the case of diffusely reflecting surfaces such as matt specular grids or reflectors and grids with enamelled surfaces, the greater the scatter capacity of the reflecting surface, the lower the proportion of directed light and the more diffuse the light becomes.

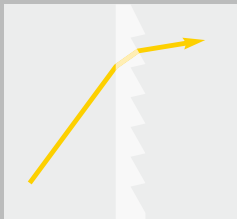

### Refraction

Glass and plastics are also used for direct light control based on refraction and total reflection of light.

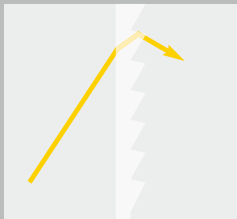

The principle of light control: When a beam of light passes from one medium into another with a different density (e.g. from air to glass and vice versa), it changes its direction based on the angle of incidence.

Prisms or lenses can also be used to bundle and scatter light and optical images.

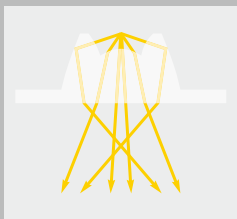

### Lenses

Lenses are used above all for point sources of light. Changing the distance between the lens and light source alters the beam angle. Such light control makes a uniform lighting design possible even with different beam angles.



### Microprisms

The light is coupled in from the side or above. The light beams are deflected precisely (asymmetrically or symmetrically). This results in defined light distribution.



71



72

# Luminaires: Certification marks and protection symbols

Luminaires are electrical appliances. Standards regulate the safety requirements to ensure adequate protection against health risks and fire and business losses.

Luminaires must ensure mechanical and electrical safety – and carry the appropriate test mark.

### ENEC and VDE certification marks

The ENEC mark (ENEC = European Norms Electrical Certification) is the European safety mark for luminaires, ballasts and starter devices, capacitors, converters and transformers and indicates uniform test conditions.

The designated number identifies the respective national certification body. In Germany, one such accredited testing and certification body is the VDE Institute in Offenbach. This issues the ENEC mark together with the inspection body number 10. ENEC and VDE marks are usually awarded in combination in Germany. Consumers can rely on the fact that products which carry these marks contain state-of-the-art technology.

certifies the quality and safety of a product, the ENEC+ mark attests to the credibility of the product data, in particular for the reliable performance of LED modules and LED luminaires. In Germany the accredited testing laboratories are the VDE and also TÜV Süd and TÜV Rheinland. The ENEC+ mark can also be obtained for conventional luminaires.

### GS mark

The GS mark stands for “tested safety” according to national and European guidelines. The GS mark can only be assigned in conjunction with the logo of the inspection body; in Germany these are the TÜV and VDE inspection bodies. Regular monitoring is conducted to maintain a certificate; this includes the monitoring of production facilities or tests to ensure that products are still in conformity with the approved type.

### CE marking

All luminaires marketed in the EU must bear the CE marking. This is not an approval

[73] EU energy label for luminaires: Since March 2014 retailed luminaires must also carry energy efficiency labels under EU regulations 874/2012 and 518/2014. These specify the type of lamp which is suitable for the luminaire.

[74] Outdoor luminaires are exposed in particular to external influences such as rain and hail. The IP number indicates the degree of protection.

### ENEC+

The ENEC+ mark was introduced in Europe in 2014. In addition to the ENEC mark that

## Luminaire labels

Manufacturer and product number

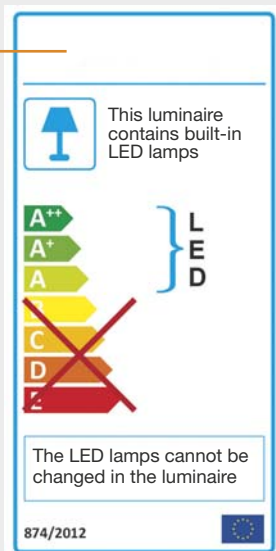

© licht.de

## Degrees of protection

1st code numeral	Protection against foreign bodies and contact	2nd code numeral	Protection against water
0	non-protected	non-protected	
1	protected against solid foreign bodies > 50 mm	protected against dripping water	☾
2	protected against solid foreign bodies > 12 mm	protected against dripping water when 15° tilted	
3	protected against solid foreign bodies > 2,5 mm	protected against spraywater	☾
4	protected against solid foreign bodies > 1 mm	protected against splashwater	☾
5	protected against dust	protected against jets of water	☾ ☾
6	dustproof	protected against powerful jets of water	☾ ☾
7	—	protected against temporary immersion	☾ ☾
8	—	protected against prolonged submersion	☾ ☾ ... m

74

© licht.de

mark, but independent confirmation by manufacturers and importers stating that their products comply with the “legal requirements” according to specific European directives.

**EMC test mark** 

Electrical devices and electronic circuits cause high-frequency electromagnetic energy that is radiated or conducted. This can cause interference leading in turn e.g. to unwanted noise on the radio or even the failure of equipment. The VDE inspection body examines whether the freedom from interference stipulated in the Wireless Protection Act is upheld and whether the device is electromagnetically compatible (EMC).

**Protection classes**

Like any other electrical device, a luminaire must be designed to protect users from electrical shock. According to DIN VDE 0711, luminaires are divided into three protection classes:

• **Protection class I** 

Protection class I offers protection through the insulation of live parts (= basic insulation) and protection from high contact voltages through the connection of touchable metal parts to the protective conductor (= earth). Mobile protection class I luminaires are equipped with a three-pin safety plug.

• **Protection class II** 

Live parts are provided with additional protective insulation in this class. Connection to the protective conductor is not allowed. Mobile protection class II luminaires are equipped with a so-called euro or round-pin attachment plug without a protective conductor.

• **Protection class III** 

Luminaires of the highest protection class are operated on a safety extra-low voltage SELV (= safety extra low voltage) that presents no danger to people (< 42 Volt). Typical examples are 12 Volt rail systems. The supply voltage is provided by a safety transformer.

**IP degrees of protection**

Luminaires must also be mechanically protected so that solid particles and moisture cannot penetrate. The IP “Ingress Protection” (see table page 38) numbering system is used to indicate the degree of protection.

An IP 20 luminaire, for instance, is protected against the ingress of solid particles > 12 mm, but not against the penetration of moisture. A damp-proof luminaire of protection class IP 65 is dust tight and protected against water jets.

**Fire safety**

When selecting luminaires, the fire safety

properties of the mounting surfaces also need to be considered. DIN EN 60598 stipulates that luminaires without a fire protection mark may only be mounted directly on standard-flammability building materials (abnormal operation 130° C; fault 180° C).

However, in locations with a high fire risk where highly inflammable substances such as textile fibres can accumulate on the luminaires, only luminaires carrying the D mark and protection class IP 5X may be installed. Such luminaires are designed so that their surfaces do not exceed the prescribed temperature limits.

**Impact resistance**

Luminaires intended for use in sports facilities where ball games are played must be impact resistant and carry the appropriate mark. This also applies for the luminaire accessories and mounting parts.

**Luminaire fire protection symbols**

Surface-mounted luminaires for mounting only on non-flammable building materials.



Recessed luminaires for mounting only in non-flammable building materials.



Thermal insulation is not permitted.



Luminaires for mounting in/on furniture where the mounting surface is non-flammable up to 180° C.



Luminaires for mounting in/on furniture where the mounting surface is non-flammable up to 95° C in normal operation.



Luminaires for locations exposed to fire hazards. Temperature of horizontal luminaire surfaces max. 90° C in normal operation. Glass surfaces of fluorescent lamps max. 150° C.



**Other symbols on luminaires**

Impact-resistant as defined by VDE, “Not for tennis” if openings > 60 mm



Protected against explosion



Max. permissible ambient temperature, deviating from 25° C

ta...° C

Non-permissible lamps



Min. clearance from illuminated surface







77

## Luminaires and their power supply units

Any discussion about “energy-efficient lighting” or “visual ergonomics” also includes electronic power supply units: in combination with economical light sources they form an energy-saving duo.

Modern, energy-efficient lighting technologies require power supply units. They cannot simply be connected to the mains like high-voltage incandescent and halogen lamps. The exceptions here are retrofit lamps with built-in power supply units (CFLi, LED retrofit). External power supply units are often built into the luminaire or incorporated in the electrical circuit.

### Electronic ballasts (EBs)

Where possible, traditional light sources are operated with electronic ballasts. This is because, besides energy efficiency, they also offer many other lighting quality benefits, such as flicker-free light as the result of their high-frequency operation. Depending on the type of the electronic ballast, the light sources can also be controlled or dimmed. However, for high-wattage high-pressure discharge lamps > 400 Watts there are currently scarcely any reliable electronic devices.

The service life is of importance here: conventional ballasts are very robust and virtually “unbreakable”. The quality of the components used in electronic ballasts,

by contrast, has a significant impact on their service life.

### LED module components

LED modules can be voltage or current controlled; components with power supply functions may be pre-installed on the module circuit board. The smarter the design of the control or driver system is with its relevant interfaces, the more adaptable it will be to the actual lighting requirements: colour control and dimming can be used to simulate daylight during the day and thus are ideal for providing health-oriented light.

### What are power supply units needed for?

Light sources have different current requirements: different lamp types such as low-voltage halogen lamps need transformers. They reduce the mains voltage of 220-240 V 50 Hz alternating current (AC) to 6, 10, 12, 24, 42 V or, in rare cases, also other safety extra-low voltages. LEDs also need transformers; in this case also with rectifier function, because LEDs need to be supplied with direct current (DC). Current-controlled LED modules need units which



78

supply constant output currents such as 350 mA, 700 mA or 1,050 mA.

Discharge lamps cannot be connected directly to the mains, either. They need a start pulse – either from an external igniter (in fluorescent lamps: starter) or from a built-in igniter or ignition mechanism. Even if the ignition were to succeed, the current strength would theoretically rise to infinity (with a relatively constant mains voltage due to the negative current/voltage characteristic of discharge lamps). In practice this means that the lamp would be destroyed at some point. Accordingly, ballasts also serve to limit the current and are therefore vital for operation of the lamp.

An electronic ballast (EB) combines a ballast and ignition mechanism in a single device. It works with high-frequency alternating voltage of 25 to 40 kHz which, in fluorescent lamps, leads to a significant reduction in power consumption, yet delivers the same luminous flux. In conventional operation, the system power consumption of a 58 W lamp + conventional ballast power loss is approx. 7-10 W = 65 – 68 W; = in electronic ballast operation, however, 50 W lamp + approx. 5 W electronic ballast power loss = 55 W, representing a saving of about 23 per cent.

#### Lighting management – Power supply unit requirements

Lighting management systems control or

regulate brightness, and sometimes also the light colour of a lighting system. The requirements essentially concern dimming: pure brightness control means allowing a light source of one colour to emit more or less light.

This is simple in the case of incandescent lamps: less current heats the filament to a lesser degree, making it emit less light. Side effect: the light colour becomes warmer. In LEDs and discharge lamps this only changes slightly or not at all during dimming. Colour changes can only be obtained by mixing light sources of different light colours (LED chips, coloured fluorescent lamps) in different states of dimming.

Some light sources such as metal halide lamps cannot be readily regulated and can only be dimmed under certain conditions and with a minor adverse colour shift towards green, whereas other light sources such as LEDs or fluorescent lamps are easily controllable.

But not all power supply units support the dimming of light sources. Conventional power supply units can only be switched in steps, such as night-time street lighting in which the lamp can be switched to 50 per cent power after a warm-up phase of at least 15 minutes. Not all electronic ballasts meet this requirement: dimmable or smart electronic ballasts are required for this. Additional colour control for LEDs

requires either an extra control unit or a suitable driver with the appropriate number of outputs.

The interfaces of the power supply units should be selected depending on the type of signal, i.e. the lighting control method. 1 – 10 V control technology is sufficient for simple dimming. DALI (Digital Addressable Lighting Interface) systems can be used to control rooms and buildings. DMX (multiplex transmission) which, like DALI, can be integrated into overall building system control systems such as KNX, is suitable for larger solutions. Each power supply unit must be able to communicate with the control components and be configured accordingly.

[77 + 78] Indoor or outdoor: Modern luminaires work with electronic power supply units. They regulate the power supply and ensure efficient operation.

# Luminaires in use

A wide variety of luminaires are available for the lighting of indoor and outdoor spaces. Sustainable solutions take into account relevant standards and photometric properties, are efficient and allow the integration of luminaires in intelligent control systems.

A luminaire combines a light source, electronics and optics. Its purpose is to protect the light source, to distribute and direct its light and to prevent glare.

The selection of appropriate lighting should be based e.g. on

- the nature of the visual tasks
- the architecture and interior design
- safety requirements
- intended uses
- biological effects

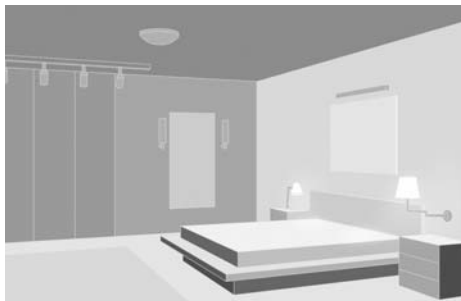

**Decorative bedside or wall lights** are indispensable in bedrooms or in hotel rooms. It should be possible to turn them on and dim them separately to ensure that the light does not disturb the person on the other side of the bed.



**Recessed and surface-mounted ceiling lights** are used for general and accent lighting. Light-directing microprisms and grids ensure good glare control.



**Downlights** are dictated by the architecture. Wide-beam downlights are used for general lighting. **Pendant lights** illuminate the dining table.



**Spotlights** provide highlights in the room and use directional light to draw attention to pictures and objects. They must be angled to avoid glare.



**Pendant lights** can be used for direct, indirect or combined lighting in almost any room. They are available with a variety of reflectors and anti-glare features.



**Floor-standing and table lamps** for living areas are versatile, decorative and create a warm atmosphere. Dimmers and light control systems provide additional comfort.



**Recessed underfit lights** are indispensable for good illumination of work surfaces, especially in the kitchen. They must be suitable for mounting into or onto furniture units.



**Luminous ceilings and recessed ceiling luminaires** emit light from a large area and are well suited for dynamically controllable and biologically effective lighting.





**Power track systems** are flexible. Luminaires and spotlights can be inserted at any point on the rails using adapters and can be used to shine light on individual locations.



**Light channels** are highly flexible: for example, long strip luminaires for general lighting can be combined with high-power spotlights to provide accent lighting.

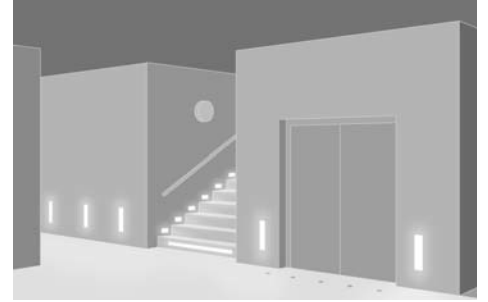

**Recessed wall and stair luminaires** emphasize the architecture and show guests and visitors the way. As additional lighting, they provide better orientation and greater safety.



**Mirror luminaires** produce high illuminance levels from an elevated position usually by means of a slightly convex mirror which distributes the light from a powerful spotlight down into the room.



**Cabinet lighting:** Fibre optic lighting systems and LED modules are particularly well suited for display cabinet illumination because of their slim dimensions.

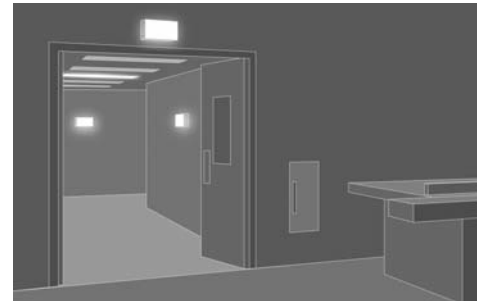

**Safety lights** ensure orientation during power failures, allowing buildings to be evacuated quickly. They must be operated independently of the mains power supply.

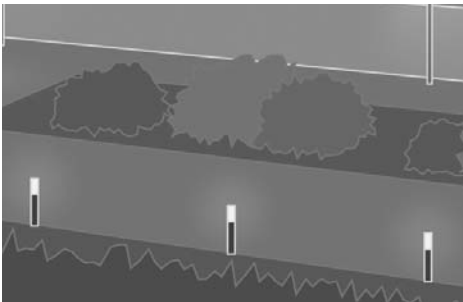

**Bollard luminaires** are frequently used both in private as well as public areas to illuminate paths. During the daytime they often also serve a decorative purpose.

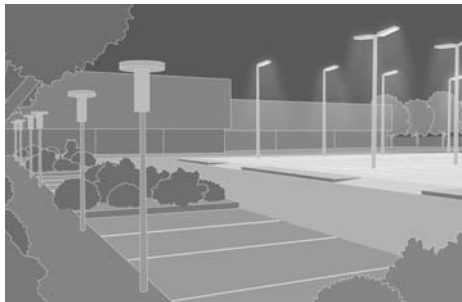

**Mast lights and light columns** are widely used. High mast lights are suitable for lighting large areas, light columns are used to illuminate paths and small car parks.



**Arm-mounted mast luminaires**, available in single or double-arm versions depending on the lighting task; can be used for universal and energy-efficient street lighting.

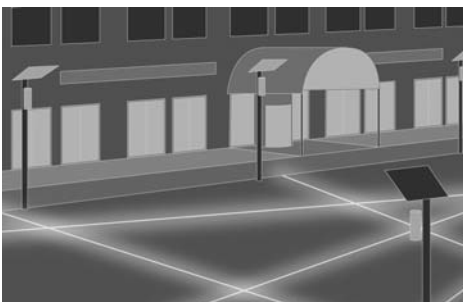

**Linear recessed floor luminaires** add a decorative accent to squares and streets. When operated with RGB control units, the light strips can also provide coloured light.

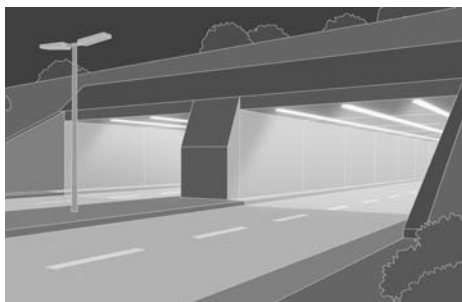

**Tunnel luminaires** operate continuously in dirty conditions. They must be particularly robust and low-maintenance. LED luminaires have many advantages here.

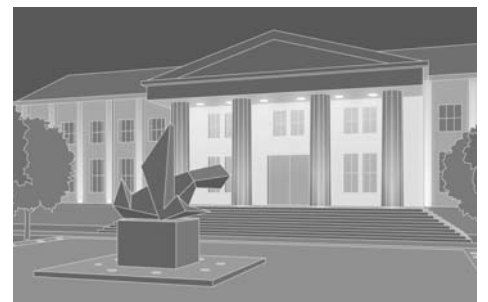

**Facade luminaires, down and uplights** Accentuate outdoor facades and accentuate details. The light also provides safety and orientation.

# Lighting design

Good lighting creates a pleasant ambience and is a prerequisite for good vision and a sense of well-being. Expert planning is required in order to meet the diverse requirements of ergonomically and photometrically perfect illumination.

What is crucial indoors is that all visual tasks – especially at work places – can be satisfactorily completed and that any disturbance, e.g. in the form of glare, is avoided where possible. New lighting concepts should be based on the specific lighting demands and focus on the individual visual tasks. The quantity and quality of the lighting can then be determined precisely for each area of the work place.

Compliance with the German work place regulation ASR A 3.4, and with the DIN EN 12464-1 standard as an accepted technical regulation is recommended for lighting design. The standard defines the lighting for the area in which the visual task or activity is performed, or the space. Achieving a balanced mix of required brightness levels is the best option for all work areas. The lighting can be designed based on one of three concepts:

- **Space-based lighting** – provides uniform lighting throughout the room and is preferable if the arrangement of the work places is not fixed or should remain flexible. Realization: direct/indirect pendant

luminaires or large luminaires recessed in or suspended from the ceiling.

- **Activity-based lighting** – focuses on the work area; this is illuminated to at least 500 lux. This variant is recommended when work places involve different visual tasks that require individual illuminance levels, or when work islands need to be separated from each other. The surrounding area is lit up to at least 300 lux. Realization: direct-radiating surface-mounted and pendant or floor luminaires with direct/indirect light distribution; downlights can be used for the surrounding area.

- **Visual task-based lighting** – is usually focused on specific areas. One such typical area would be the work area on the desk-top. This can easily be lit using individually adjustable desk lamps.

Complex lighting tasks require specialist expertise. Qualified planners should therefore be charged with the lighting design; these should have attended appropriate training courses and hold relevant certification. They should be familiar not only with

the current state of the art, but also the relevant rules and standards which must be observed. It is also important that all those involved work together from the outset on an interdisciplinary basis. The lighting concept should always be preceded by an analysis:

- Which activities and visual tasks need to be carried out where?
- What are the users' and investors' needs?
- What architectural, furniture or machinery requirements need to be taken into consideration?

Only when the lighting concept has been drawn up can suitable light sources and luminaires be selected. First, the number of light sources for the required illuminance needs to be calculated, then the number, type and arrangement of the luminaires decided and appropriate lighting management systems chosen. These are indispensable if dynamic light scenarios or biologically effective lighting are to be created.

## Computer-based planning

The lumen method can be used to determine the number of luminaires necessary

[79] Lighting design is carried out today using computers. Special programs are used to make photometric calculations and deliver realistic simulations e.g. an urban square with adjacent road, as shown in the example.



for standard-compliant lighting (= average illuminance). There are various computer programs which can be used to calculate the spatial distribution of the illuminance.

Such planning software allows the complete photometric calculation of a lighting system based on menu-driven entries – from a preliminary assessment through to detailed photometric documentation of a project including lists of materials. Graphic representations provide a clear image of the lighting system.

### Street lighting

Street lighting is used to ensure traffic safety at night. During the hours of darkness it enables or enhances the acquisition of information. The overriding principle is: “see – and be seen – clearly”.

The lighting system is designed based on the hazard potential and the visual tasks of the primary users. The risk increases along with rising traffic volumes and different types of road users such as motorists, cyclists and pedestrians. A clear overview of the street and possible conflict zones is a key factor in determining the level of lighting.

Expressed in simple terms: the greater the risk of an accident, the more light is needed for street lighting. Standards such as DIN EN 13201-1 contain classification information. The relevant requirements and the minimum photometric values are deter-

mined in a step-by-step selection procedure. The goal of lighting planning is to obtain the required quality characteristics of the particular lighting situation – such as illuminance, luminance, total and longitudinal uniformity and glare control.

Optimum mast positioning, light point heights, light intensity distribution and luminous flux will yield a viable economic solution. The change to modern street lighting with long-life lamps, high luminous efficacy and optimal light control yields significant savings for local authorities. Possible ways of saving energy and money with modern technology range from reducing circuits through to lighting management systems.

 *More information about street lighting can be found in licht.wissen issue 03 “Roads, paths and squares”; licht.wissen 04 provides information on office lighting, while licht.wissen 05 is about lighting of industrial sites. With regard to lighting of work places, licht.de has published the “Guide to DIN EN 12464-1”.*

## Lighting design based on the lumen method

The publication “Projektierung von Beleuchtungsanlagen nach dem Wirkungsgradverfahren” (Engl.: Design of lighting systems based on the lumen method) issued by Deutsche Lichttechnische Gesellschaft LiTG e.V. describes the operation and gives utilization levels for a number of standard luminaires.

The required number of luminaires is calculated based on the desired illuminance using the following formula:

$$n = \frac{E \cdot A}{z \cdot \Phi \cdot \eta_B \cdot WF}$$

in which:

- n = Number of luminaires
- E = Illuminance
- A = Area or section of area
- z = Number of lamps per luminaire
- Φ = Luminous flux of a lamp
- η<sub>B</sub> = Utilization factor (= luminaire light output ratio [= η<sub>LB</sub>] x utilisation [= η<sub>R</sub>])
- WF = Maintenance factor

Utilance is a function of the luminous flux distributed by the luminaire, the geometry of the room and the reflectance of room surfaces. The luminaire manufacturers provide information on the utilization factor.

## Lighting design

[80] An office work place consists of work and circulation areas and related utility space (shown in orange). This is enclosed by the surrounding area which extends up to the room limits. This definition fulfils the requirements of DIN EN 12464-1 for office work places. A strip of 0.5 metres around the walls can be ignored in the calculation if no visual task areas are located within it.

Work places should be illuminated to at least 500 lux; demanding visual tasks require areas of at least 750 lux. The lighting requirements in the immediate surrounding area are lower, with illuminance levels of at least 300 lux sufficing.

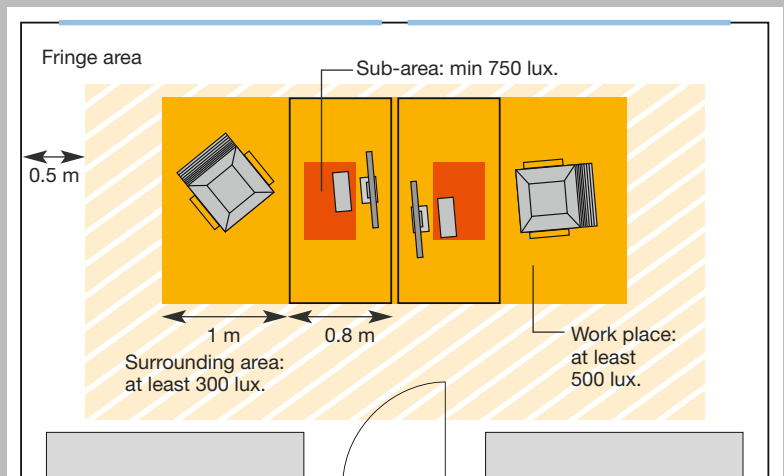





81

## Lighting management – convenient and efficient

Needs-based and extremely convenient, ergonomic and efficient: customized lighting management systems make lighting flexible and sustainable.

Modern lighting management makes lighting intelligent. Digital control ensures that the right light is always available at the right time in the right quantity: for concentrated work in the morning with bright, energising daylight, and relaxation in the evening with cosy and warm lighting. The right light supports people not only in their visual tasks. It also creates a pleasant atmosphere and promotes well-being because light also influences our biological rhythm – our “inner clock”.

Lighting is adapting more and more to specific requirements and needs. Depending on the scale and the requirements, lighting solutions can be realized for luminaires, single rooms or complex buildings – and controlled with maximum convenience by smartphone. The components of lighting management are:

- Pre-set light scenes for different activities (e.g. in conference rooms) and display scenarios (e.g. shop windows or facades);
- Motion detectors. These ensure that

light is only turned on when someone is in the room or enters a specific outdoor area;

- Control of the lighting level depending on the amount of available daylight, through dimming or partial switch-off.

### Lighting management saves energy.

Natural light is available free of charge, has a positive effect on people’s sense of well-being and is required by the German work place regulation ASR A3 4. Sensors measure the natural brightness in rooms and outdoors; artificial light is switched on or dimmed as required.

At safety-critical points where the light may not be switched off, it should be possible to radically reduce the lighting level. Presence detectors and dedicated dimming systems are used in combination with timers. This allows the power consumption of individual luminaires to be reduced by up to 50 percent of the installed capacity, without the user noticing any loss of lighting quality.

### More safety

In urban street lighting, too, lighting management systems offer many advantages. Individual points of light or groups of lights can be switched on or off or dimmed to adapt the lighting level to actual requirements. The lighting level is raised at critical points during heavy traffic where there is an increased risk of accidents or during unfavourable weather, and lowered again during slack periods. A maintenance plan has been drawn up; defective light sources are automatically reported.

Burglary protection is also possible. A security service, for instance, can use the system to turn on the lighting. Safety lighting can be directly integrated and special requirements for hazardous jobs, such as milling, taken into account.

### Lighting management for well-being

Intelligent light control systems are increasingly being deployed in interior lighting to create biologically effective lighting based on the model of daylight. Changing bright-



82



83



84

ness and light colours motivate people and support their health in a natural way, especially in low-light areas in work places, at school or in care environments. Large expanses of daylight white light with a high proportion of blue of at least 5,300 kelvins enhances concentration during the day. In the evening, warm light colours (up to 3,300 kelvins) and low illuminances prepare the body for sleep.

 *Lighting management is the subject of licht.wissen 12; biologically effective light is covered in licht.wissen 19.*

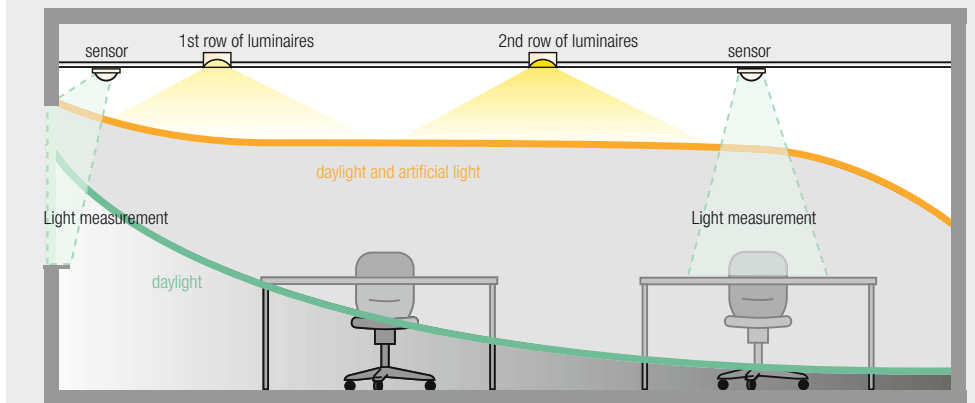

85

© licht.de

[81] Flexible light for the latest fashions: The light colour and brightness of the LED lighting match the collection and the time of day.

[82 – 84] Biologically effective lighting with changing light colours and brightness levels supports the day-night rhythm of patients and aids recovery.

[85] Daylight-related light control saves energy: Light sensors at windows and in the room measure the amount of light and control the lighting based on the level of incident daylight.

[86] Smart lighting: Simple solutions can be conveniently controlled using a smartphone.

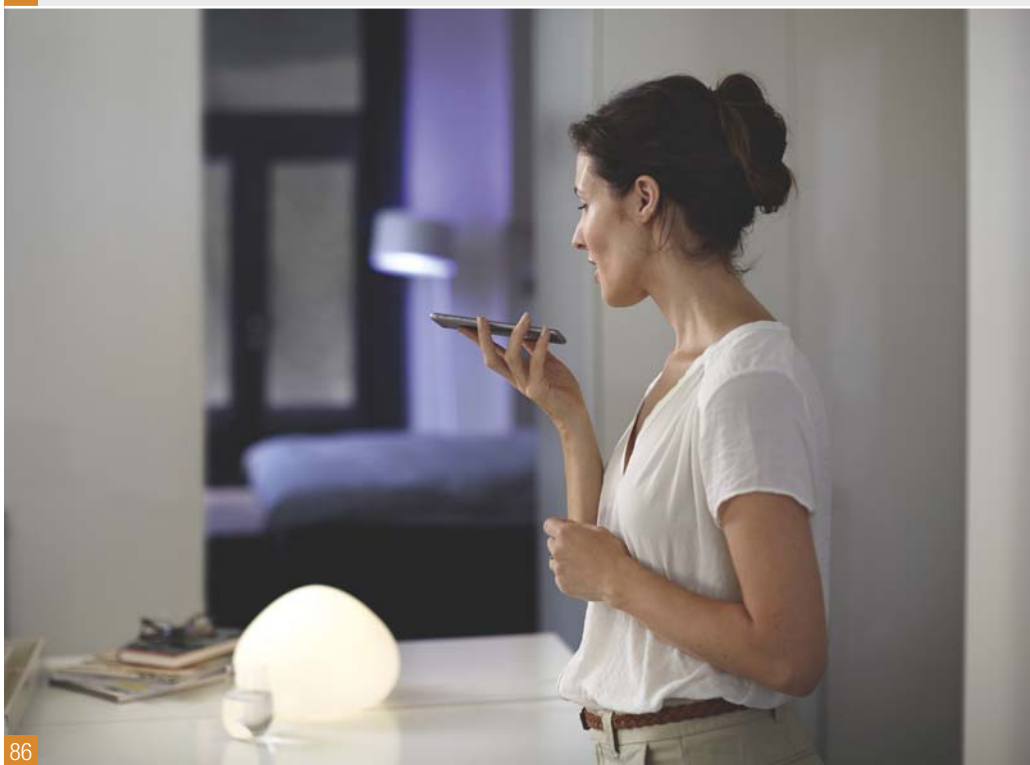

86

# Energy-efficient lighting

High energy efficiency is obtained through a combination of a high-efficiency luminaire system, needs-based use and high-quality lighting. This helps protect the environment.

Nowadays one of the quality characteristics of a lighting system is low energy consumption. The use of efficient lighting technology and the intelligent exploitation of natural light protect the environment and reduce costs.

## Better light quality, lower costs

The corresponding lighting technology is available. The charts on page 49 show the potential savings yielded by the individual measures. The following components are involved:

- Luminaires with high light output ratios and optimized light control through appropriate grids and reflectors,
- Efficient light sources with high luminous efficacy levels (such as LED modules),
- Modern electronic power supply units and ballasts
- Intelligently planned lighting concepts with multiple switching groups which can be dimmed and controlled separately and independently of each other
- Lighting management systems that include daylight and presence sensors.

Control systems offer a high degree of convenience and maximum potential for

savings. Presence detectors ensure that lights are automatically dimmed or turned off when no light is needed. The use of natural daylight yields even greater efficiency. In combination with a lighting management system, energy requirements can be reduced by up to 80 percent in comparison to a conventional system.

Lighting management systems are available in different configurations (*see also page 46f.*). These range from the simple regulation of individual luminaires to complex systems that are integrated into the building system technology.

## EnEV (Energy Saving Ordinance): Saving energy obligatory

The current version of the Energy Saving Ordinance (EnEV) from October 2014 makes the efficient use of resources mandatory. It puts a cap on the maximum allowable total energy requirement of buildings, including lighting. According to the "EnEV", an energy performance certificate must be drawn up for each building, and the primary or actual energy consumption of the lighting always determined before new construction or renovation. The cal-

[87] A positive example: During the day the office space is lit by natural daylight – supported by LEDs and intelligent lighting management which effectively ensures good working conditions.

[89 + 90] A change to energy-efficient lamps in combination with modern lighting management saves up to 80% power and operating costs in both indoor and outdoor lighting.







calculation method used is that given in DIN V 18599 “Energy efficiency of buildings – Calculation of the energy needs, delivered energy and primary energy for heating, cooling, ventilation, domestic hot water and lighting”. Part 4 deals with the net and final energy demand for lighting.

### Lighting quality has top priority

Saving energy is important. But the quality of the lighting should not suffer because of savings measures. For this reason photometric quality parameters (see also page 15) have been defined for artificial lighting (and also for incident daylight). Because light is planned for people, and as such it needs to be fit for purpose – not only in the world of work. It should satisfy exacting visual ergonomics demands, promote well-being and maintain health.

 Information about sustainable lighting can be found in *licht.wissen 20*; Lighting management is covered in *licht.wissen 12*.

 More information about the renovation of lighting facilities, budgeting and financing is provided by the german “dena-Lotsen” on indoor and street lighting ([www.lotse-innenbeleuchtung.de](http://www.lotse-innenbeleuchtung.de) / [www.lotse-strassenbeleuchtung.de](http://www.lotse-strassenbeleuchtung.de)).



### Savings potential of interior lighting

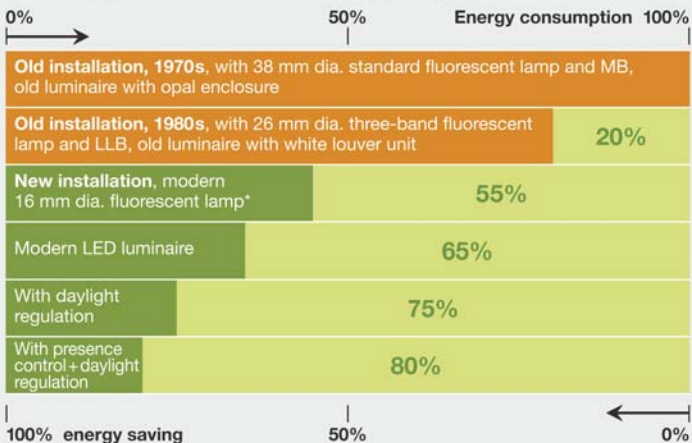

\* Fluorescent lamp operated by EB with very low power loss, energy-efficient direct or direct/indirect luminaires with modern optical control technology © licht.de

### Savings potential of exterior lighting

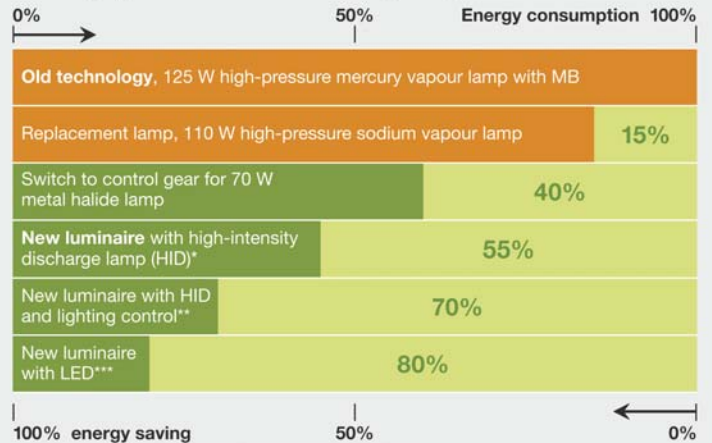

\* High-pressure sodium vapour lamp or metal halide lamp  
 \*\* High-pressure sodium vapour lamp or metal halide lamp, with control system and 50% output for 2,000 hrs  
 \*\*\* With control system and 50% output for 2,000 hrs © licht.de

# Sustainable lighting technology – “green” and good

Modern light sources and efficient lighting control consume little energy and relieve the strain on the environment. But “green” lighting can do even more: its impressive effects include good LCAs, cost savings and improved quality of life.

Each kilowatt hour of electricity that is saved reduces carbon dioxide (CO<sub>2</sub>) emissions. That is why saving energy also helps protect the climate – and why it is of relevance throughout Europe. The European Commission has ambitious objectives in this area. In the “Roadmap for moving to a competitive low carbon economy in 2050” it explores new ways of reducing greenhouse gas emissions by 80 to 95 percent.

### Protecting resources

According to the International Energy Agency (IEA) the proportion of lighting to global electricity consumption has already decreased from its original figure of approximately 19% to 15% (2014). Modern lighting technology offers the potential for major savings and can make a major contribution to sustainable growth. Efficient light sources, optimized luminaires and electronic control help conserve natural resources, can be recycled, and save costs. They make visual tasks easier and promote a sense of well-being. Effective control also ensures that lights are only switched on when they are needed.

### Eco-design Directive (ErP):

#### Saving energy obligatory

Increasingly, European and national legislation is committing municipalities, companies and private households to the intelligent use of energy. Energy-wasting products are now gradually being banished from the shelves. These include inefficient high-pressure mercury vapour lamps which were banned in 2015.

The framework for the ecodesign of energy-related products is laid down in the Eco-design Directive – or more correctly: ErP Directive (Energy-related Products Directive 2005/32/EC). It came into force in November 2009 and replaced the former EuP (Energy-using Products) Directive. Manufacturers are obliged to provide technical information about their product in accompanying documentation and on the internet.

### LEDs save large amounts of CO<sub>2</sub>

In its study first published in August 2011 (and later updated in 2012) entitled “Lighting the way: Perspectives on the global lighting market”, the consulting firm

[91] Study by Prof. Dr. Gerhard Eisenbeis on the insect compatibility of LEDs compared to conventional light sources. During the test period (summer 2011) in Frankfurt, insect traps were attached to the relevant light sources; these were emptied daily and the yield counted. The best result was achieved by warm-white LEDs.

[92 + 93] Energy-efficient LEDs and precisely aligned reflector lamps save energy, help in the battle against light pollution and protect nocturnal insects.

## Testing of photobiological safety

Non-visible radiation is always emitted by the light sources designed for general lighting, e.g. below 380 nm ultraviolet (UV) and above 780 nm infrared (IR) radiation. Blue components in visible light also represent a certain danger to the eyes and skin.

Since 2011, testing of photobiological safety in accordance with DIN EN 62471 has been prescribed in the Low Voltage Directive 2006/95/EC and is therefore binding for the CE marking of light sources, luminaires and lighting systems.

Insect numbers with different light sources

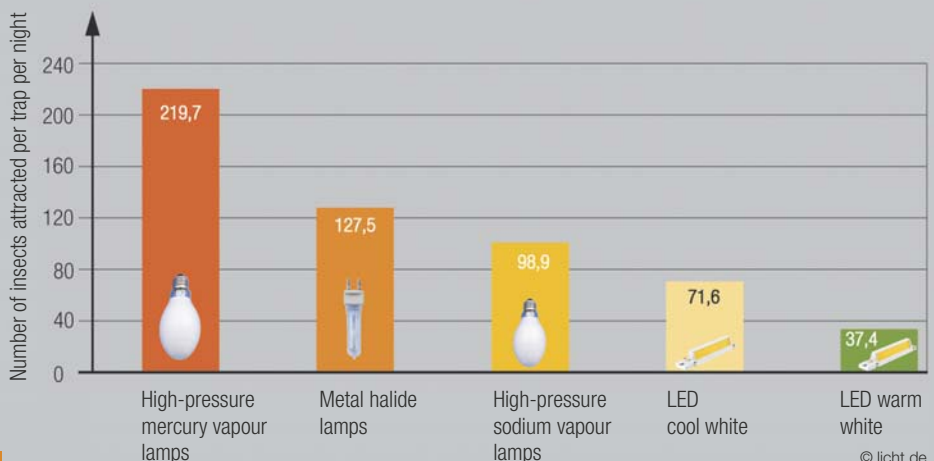

McKinsey described how LED-based lighting solutions offer the highest potential CO<sub>2</sub> savings compared to other future lighting industry climate protection measures. The study concludes that saving one tonne of CO<sub>2</sub> per year through energy-efficient LED lighting incurs only a fifth of the costs that would be required to save the same amount of CO<sub>2</sub> through the use of solar systems.

LEDs are also perceived as pleasant. The Federal Ministry of Education and Research (BMBF) launched its “Municipalities in a new light” competition to determine (among other things) the acceptance of LED lighting compared to conventional technology. A high proportion of those surveyed preferred LED lighting, especially with regard to its colour fidelity, brightness and sense of safety.

#### Avoiding light pollution

In outdoor lighting, LED technology and digital control systems ensure high efficiency, but through precise light control they can also avoid unwanted light emissions (that are increasingly frowned upon as “light pollution”, especially in metropolitan areas) and protect nocturnal insects.

Light pollution should be excluded right from the planning stage of a lighting system. In Germany, however, there are currently no specific limits on light pollution, either in the form of laws or administrative regulations. Alternatively, measurement and evaluation

methods and the maximum permissible LiTG values derived from these can be used for analysis (= Lichttechnische Gesellschaft, Publication No. 17/1998; www.litg.de). Also of relevance are the “Light emission measurement and assessment guidelines” (Richtlinie zur Messung und Beurteilung von Lichtimmissionen), last updated in 2012, which the Länder Committee for Pollution Control (LAI) recommended the environmental authorities to apply. Several European countries, including the Czech Republic, Italy and Spain, have already enacted laws to protect the night sky.

#### Protecting insect habitats

Artificial lighting attracts insects. Night lighting therefore carries the risk of disrupting the natural rhythm of most nocturnal insects. Insect eyes are more sensitive to the spectral composition of light. According to studies, they are far less attracted to LED light since it contains no UV radiation (see figure 91).

#### What to do with old lamps and luminaires?

Making sustainable use of resources also includes the recycling of raw materials. The Electrical and Electronic Equipment Act (ElektroG) regulates the return and environment-friendly disposal and recycling of corresponding devices. The respective manufacturers or importers are responsible for this. They can also delegate the task to third parties. Disused lamps and luminaires

from street lights, for example, are taken in by the Lightcycle-Retourlogistik und Service GmbH joint venture (www.lightcycle.de). The ZVEI provides information on disposal at www.zvei.org.

#### Harmful substances in lamps

The revised version of the RoHS Directive (Restriction of the Use of Certain Hazardous Substances) issued in May 2011 obliges producers of light sources throughout Europe only to use predetermined minimum amounts of harmful substances such as lead, mercury, nickel and cadmium.

 More information is available in *licht.wissen 20* “Sustainable lighting”; information on LED technology can be found in the ZVEI Guide “Planning security in LED lighting: Terms, definitions and measurement methods”. Both publications can be downloaded from [www.licht.de](http://www.licht.de).

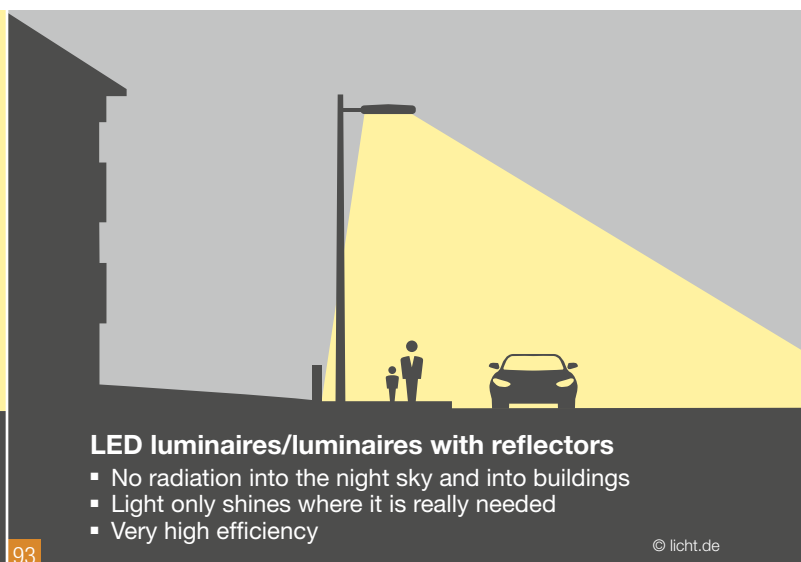
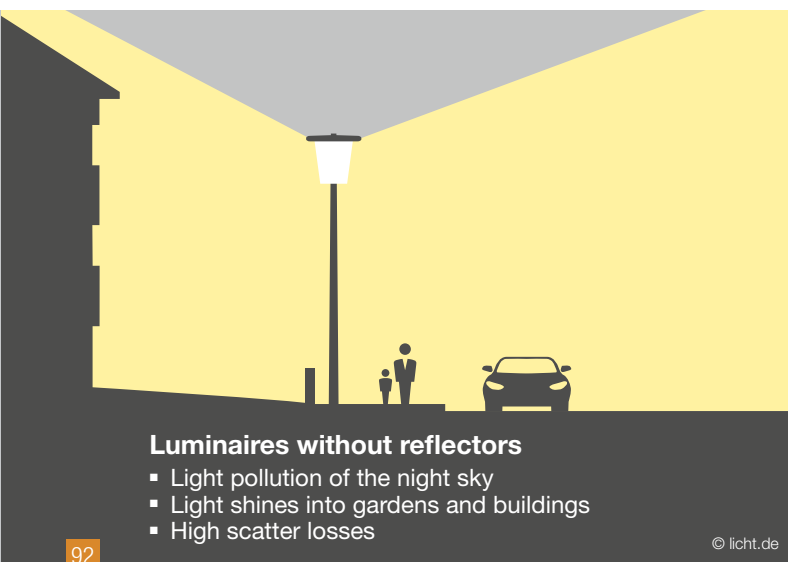



# Lighting costs

Whether new systems are being installed or old systems refurbished, any decisions must be based on a detailed analysis of the lighting costs – and all the influencing factors. In the case of refurbishment, these include a comparison with the old system. Operation generally accounts for the greater part of the costs.

Once the photometric specifications have been laid down, the planners and decision-makers then have to draw up a cost estimate and calculate the efficiency of a lighting system. The best tool for this is a cost analysis covering the entire life cycle – from product selection and operation through to disposal. This compares not only the procurement costs, but also includes all further costs such as investment, energy, maintenance and disposal. This permits proper assessment of the efficiency of a system.

Important to know. In an age of rising electricity prices and highly efficient lighting solutions, the operating expenses for energy, maintenance and repairs represent around 80 per cent of the total life cycle costs; procurement and installation only account for roughly 20 per cent. The energy costs constitute a dominant part of the operating costs. This is therefore where the biggest savings can be made if spending on lighting is to be permanently reduced – a compelling argument for the

use of energy-efficient lighting based on LEDs and intelligent lighting management.

### Determining the observation period

An important factor in the life cycle analysis is determining a suitable observation period. This should be in line with the economic horizon of the end user or the application. This is particularly true in the case of projects in rented premises. Here there is an investor/tenant dilemma, as it is the tenant and not the investor who benefits from the savings. 50:50 models have been devised for such situations which ensure that both sides benefit from the savings.

Many investors hesitate to set periods of more than five years because they themselves find it difficult to generate an accurate forecast over a very long time in a rapidly changing world. In this case, it is advisable to choose an observation period which is about 30 to 50 per cent longer than the payback period of the simplest lighting solution. This ensures that even

investment-intensive solutions which offer greater savings (such as lighting control systems) can prove their efficiency and be implemented.

As a rule of thumb: the longer the period defined, the easier it is to select optimized solutions which require higher initial investment.

### Costs over the life cycle

Relevant cost factors in a life cycle analysis are maintenance, energy, repair, interest and procurement costs, subsidies and the expenses arising from removal and disposal. Luminaire manufacturers must provide information about the failure rate of their products. Any replacement costs should also be taken into account in the analysis.

An analysis of all costs over the entire life cycle reveals that systems with a higher initial investment and consequently a longer payback period can, in the long run, save even more costs than systems that pay for



themselves faster. The payback period as a decision-making parameter therefore usually yields only the simplest alternative, but rarely the best and most attractive long-term solution.

Thus, high-quality LED luminaires and a lighting management system are usually more expensive to procure, yet represent an attractive proposition with the lowest life cycle costs in the long term thanks to their high efficiency and low maintenance costs. They also offer consistently higher light quality – an advantage in terms of people’s sense of well-being.



95

### Cost distribution in the life cycle of a street lamp

Life cycle costs (TCO = Total Cost of Ownership) arise over a defined period of time (e.g. 20 years) and include the total cost of investment plus operation (including energy costs) and disposal



#### Investment costs

- Equipment costs
- Installation costs

#### Operating Costs

- Energy costs
- Maintenance costs
- Spare part costs
- Ordering costs
- Storage costs

#### Costs at end of service life

- Disposal costs
- Dismantling costs

© licht.de

96

[94 + 95] Modern LED luminaires save electricity, reduce operating costs and emit pleasantly bright light.

[96] The investment costs play only a secondary role when the costs of the entire life cycle are considered. Modern technology usually costs more to purchase, but excels in operation through its high efficiency and superior lighting quality.

# To the point. Measuring lighting systems

Methods have been developed for the assessment of lighting systems which are aimed especially at professional users such as architects, lighting designers and installers.

The purpose of taking measurements is to assess the current state of an existing lighting system in order to obtain information on its maintenance, servicing or renewal requirements. They also permit different lighting systems to be compared and the light quality of new lighting projects to be assessed.

The key parameters for uniform evaluation of lighting quality are defined in the relevant standards and regulations:

- **Illuminance E**, e.g. as horizontal illuminance  $E_h$ , as vertical illuminance  $E_v$ , as cylindrical illuminance  $E_z$  or semi-cylindrical illuminance  $E_{hz}$
- **Luminance L** – e.g. in street lighting, tunnel lighting or interior lighting
- **Reflectance  $\rho$**  – e.g. of ceilings, walls and floors inside work places and sports halls
- The **reflective properties** of road surfaces – e.g. in street and tunnel lighting
- The **mains voltage U and/or the ambient temperature  $t_a$**  for lighting systems with lamps, the luminous flux of which is dependent on the supply voltage and/or the room or ambient temperature.

## Preparing for measurements

In practice, the variable measured most frequently is illuminance. Instruments – known as lux meters – are configured to the spectral light sensitivity level  $V(\lambda)$  of the human eye and simulate its light sensitivity. They must also measure oblique incident light in line with the cosine law.

Light measurements can also theoretically be made using a smartphone and corresponding apps. In practice, however, these often yield grave measuring errors (of 50 per cent and over).

The following information is collected prior to each measurement:

- Geometric dimensions of the lighting system

- Type of room and the activities performed there
- Variables to be measured and location of measuring points
- General condition of the system, including age, the date of the last cleaning and the last lamp replacement, degree of soiling.

Daylight should always be shaded for such measurements. Measurements undertaken during the hours of darkness or with the windows covered by opaque covers are ideal. If this is not possible the illuminance must be measured with the lighting system switched on and immediately again with it switched off. The difference in the measured values corresponds to the illuminance of the artificial light. Before the measurements are made, the mains voltage and ambient temperature should also be checked. Furthermore, new light sources which have already been “run in” should be used (discharge lamps = at least 100 hours operation).

## Measurement grid and measurement heights

To measure the illuminance levels, the floor of a room should be divided into individual squares. This measurement grid should not be identical to the grid size of the luminaire arrangement in order to avoid only maximum values being measured directly beneath luminaires. However, symmetries between the lighting and the room or outdoor spaces can be exploited to obtain a useful reduction in the number of measurements required. Requirements regarding

Room length	Measuring point distance
5 m	0.5 m
10 m	1 m
50 m	3 m



the measurement grid can be found in DIN EN 12464 and DIN EN 12193.

The measured values are represented in tabular form. A graphical representation of the illuminance in isolux curves is obtained by joining up measurement points of the same illuminance.

The uniformity of illuminance  $U_o$  is the quotient of the lowest measured illuminance  $E_{min}$  and the calculated mean illuminance  $E$ .

#### Create measurement log

A log should be created for each measurement. This should contain e.g. the measured values but also the

- Ambient conditions
  - Information on light sources, luminaires and the geometry of the lighting system
- Entering not only the lighting quality characteristics, but also noting all technical data of a system (e.g. operating hours per year, electricity costs, cleaning cycles and maintenance factors) will result in an easy-to-update overview which can be used as the basis for making economic decisions.

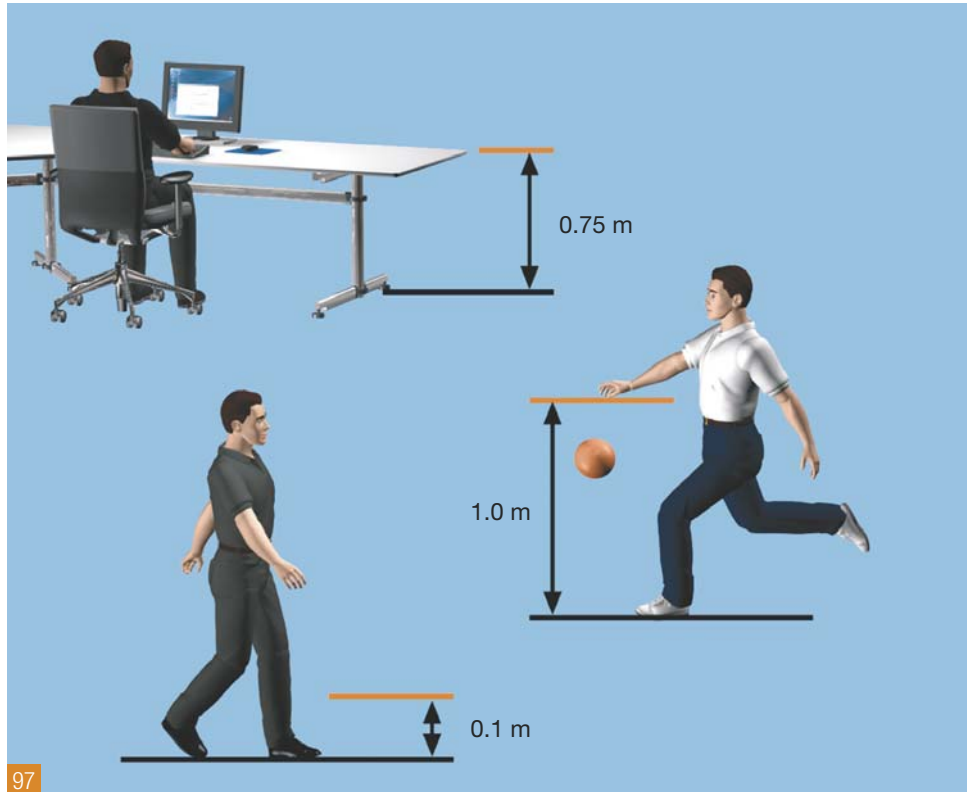

97

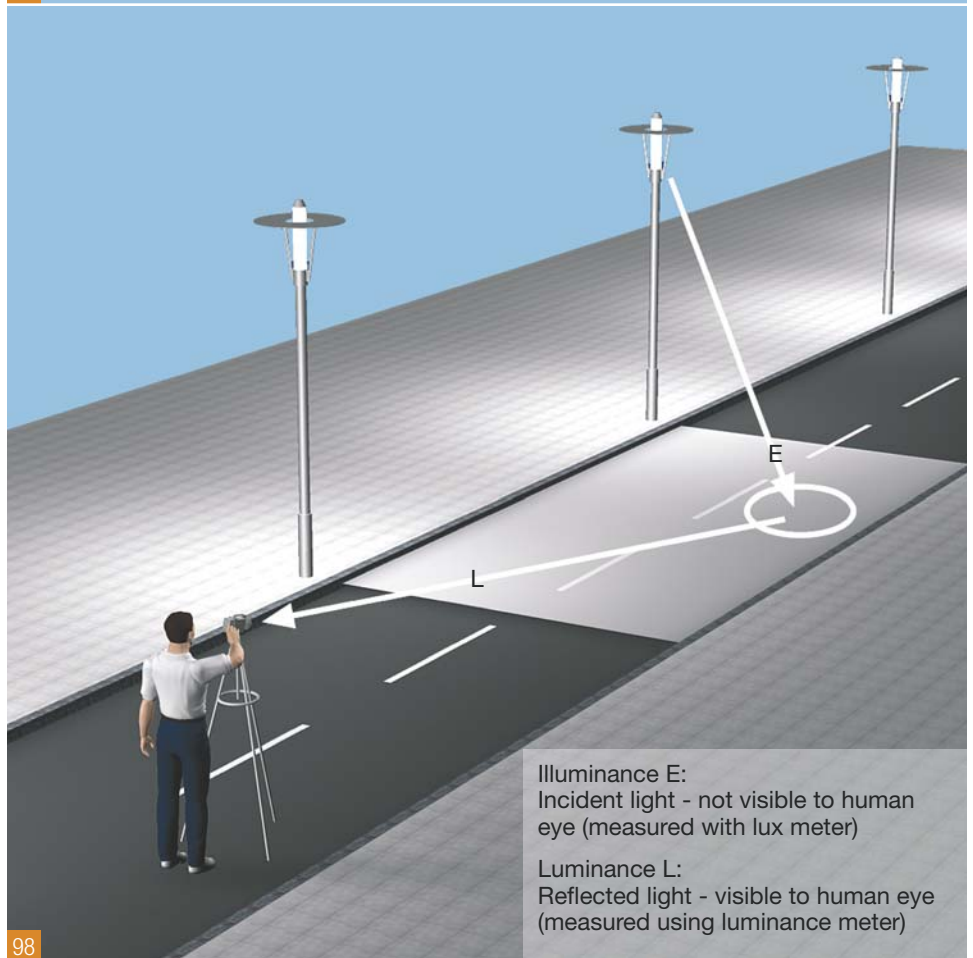

98

**Illuminance E:**  
Incident light - not visible to human eye (measured with lux meter)

**Luminance L:**  
Reflected light - visible to human eye (measured using luminance meter)

[97] Horizontal illuminance levels are measured in indoor environments (work places) 0.75 m above the ground and 0.1 m above the ground on thoroughfares, streets and parking areas. Vertical illuminance levels at indoor and outdoor sports facilities are measured 1.0 m above the ground.

[98] For street lighting system assessment, the luminance L of the road surface/roadway is measured using a luminance meter.

### Light meters and their accuracy

Class	Quality	Application
A	High	Precision photometry
B	Medium	Operating photometry
C	Low	Rough photometry



## Standards, regulations and literature

Artificial lighting is complex. Standards and ordinances regulate the requirements concerning the components of lighting systems and for indoor or outdoor lighting.

### Basic standards for lighting

The current versions of the DIN standards of the German Institute for Standardisation (Deutsches Institut für Normung e.V.) are available from  
Beuth Verlag GmbH,  
Burggrafenstraße 6, 10787  
Berlin, www.Beuth.de.

#### DIN EN 12665 (2011)

Light and lighting – Basic terms and criteria for specifying lighting requirements

#### DIN 5032-1 (1999)

Photometry – Part 1:  
Methods of measurement

#### DIN 5032-4 (1999)

Photometry – Part 4:  
Measurements of luminaires

#### DIN 5032-9 (2015)

Photometry – Part 9:  
Measurement of the photometric quantities of incoherent emitting semiconductor light sources

#### DIN SPEC 5031-100 (2015)

Optical radiation physics and illuminating engineering Part 100:  
Melanopic effects of ocular light on human beings – Quantities, symbols and action spectra

### Standards for indoor and outdoor areas

#### DIN EN 12464-1 (2014)

Light and lighting –  
Lighting of work places –  
Part 1: Indoor work places  
Part 2: Outdoor work places

#### DIN SPEC 67600 (2013)

Biologically effective illumination –  
Design guidelines

#### DIN 5035-3 (2006)

Artificial lighting –  
Lighting of health care premises

#### DIN 5035-6 (2006)

Artificial lighting –  
Measurement and evaluation

#### DIN 5035-7 (2004)

Artificial lighting – Lighting of interiors with visual displays work stations  
*(The standard may only be applied if the requirement does not conflict with DIN EN 12464-1)*

#### DIN 5035-8 (2007)

Artificial lighting – Work place luminaires –  
Requirements, recommendations and proofing

#### DIN EN 1838 (2013)

Lighting applications – Emergency lighting

#### DIN EN 12193 (2007)

Light and lighting – Sports lighting

#### DIN EN 13201 series (2004ff.)

Road lighting – Parts 1 to 5

#### DIN EN 13032 series

Light and lighting – Measurement and presentation of photometric data of lamps and luminaires – Parts 1 to 4

### Technical Regulations for Workplaces (ASR)

The Technical Regulations for Workplaces (ASR) are drawn up or adapted by ASTA (Committee for Work Places) and published by the Federal Ministry of Labour and Social Affairs.

#### ASR A3.4 “Lighting”

ASR A3.4/3 “Safety lighting, optical safety systems”

### LiTG publications

Address of Deutsche Lichttechnische Gesellschaft e.V. (LiTG):  
Burggrafenstraße 6, 10787 Berlin,  
www.litg.de.

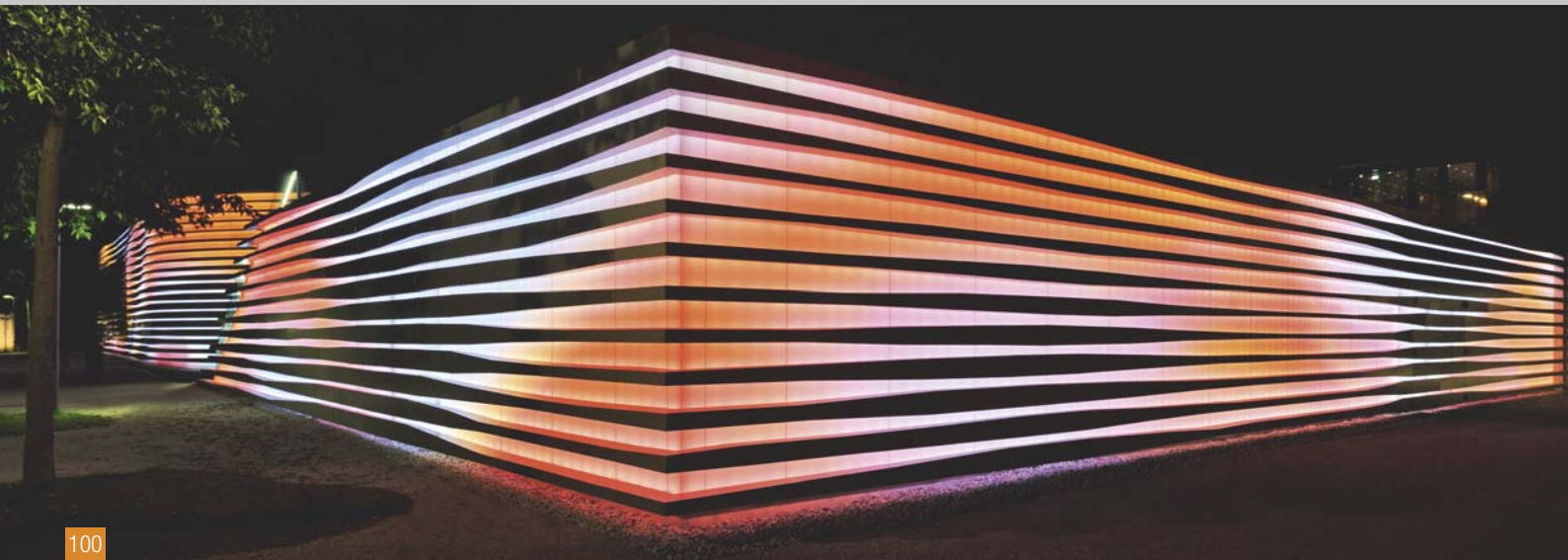

100

Publication 12.3:2011

**“Measurement and assessment of light emissions from artificial light sources”**

Publication 13:1991

**“Contrast rendering factor CRF – an interior lighting quality factor”**

Publication 18:1999

**“Methods for calculating horizontal illuminance in interiors”**

Publication 20:2003

**“The UGR method of assessing direct glare from artificial lighting in interiors”**

Publication 25:2011

**“Assessment of the photobiological safety of lamps and luminaires”**

Publication 27:2015

**“Selected light measurement topics”**

Publication 31:2015

**“Colour quality: definition and applications”**

Publication 17:1998

**“Street lighting and safety”**

## EU regulations

### Commission Regulation (EU)

**No. 1194/2012** of 12 December 2012 implementing Directive 2009/125/EC of the European Parliament and of the Council with regard to ecodesign requirements for directional lamps, light emitting diode lamps and related equipment.

### Commission Regulation (EC)

**No. 245/2009** of 18 March 2009 implementing Directive 2005/32/EC of the European Parliament and of the Council with regard to the setting of eco-design requirements of fluorescent lamps without integrated ballast, high-pressure discharge lamps and ballasts and lights to their operation and repealing Directive 2000/55/EC of the European Parliament and of the Council.

### Commission Delegated Regulation (EU)

**No. 874/2012** of 12 July 2012 supplementing Directive 2010/30/EU of the European Parliament and of the Council with regard to energy labelling of electrical lamps and luminaires.

### Commission Regulation (EC)

**No. 859/2009** of 18 September 2009 amending Regulation (EC) No 244/2009 as regards the ecodesign requirements on ultraviolet radiation of non-directional household lamps.

### Commission Delegated Regulation (EU)

**No. 518/2014** of 5 March 2014 amending Commission Delegated Regulations (EU) No 1059/2010, (EU) No 1060/2010, (EU) No 1061/2010, (EU) No 1062/2010, (EU) No 626/2011, (EU) No 392/2012, (EU) No 874/2012, (EU) No 665/2013, (EU) No 811/2013 and (EU) No 812/2013 with regard to labelling of energy-related products on the internet Text with EEA relevance.

### Commission Regulation (EU)

**No. 347/2010** of 21 April 2010 amending Commission Regulation (EC) No 245/2009 as regards the ecodesign requirements

for fluorescent lamps without integrated ballast, for high intensity discharge lamps, and for ballasts and luminaires able to operate such lamps.

## Further information

### Guide to “Reliable Planning with LED Lighting: Terminology, definitions and measurement methods.”

Fachverband Licht im Zentralverband Elektrotechnik- und Elektronikindustrie e.V., 2015 ([www.zvei.org](http://www.zvei.org))

### “Photobiological Safety of Lighting Products”,

ZVEI, 2014 ([www.zvei.org](http://www.zvei.org))

### “Ecodesign Requirements for Directional Lamps, Light Emitting Diode Lamps and Related Requirements”,

LightingEurope, 2013 ([www.lightingeurope.org](http://www.lightingeurope.org))

[99 + 100] LED media façade luminaires: As darkness approaches, the facade presents an impressive display of colours. A control system even allows moving images to be shown. The lighting is as exceptional as it is energy-efficient.



# licht.de publications

Per issue!

€ 10,-

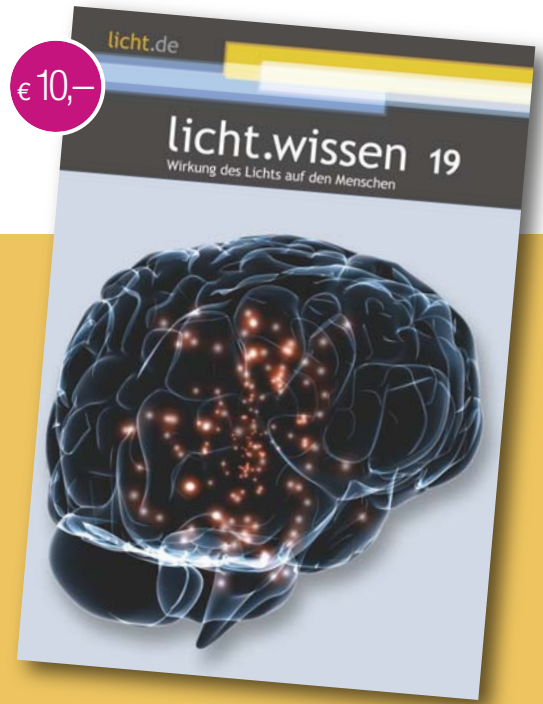

## licht.wissen 19

Impact of Light on Human Beings

56 pages on the biological impact of light on human beings: Booklet 19 reports on the current state of research and uses real-life examples to explain how melanopic lighting should be approached.

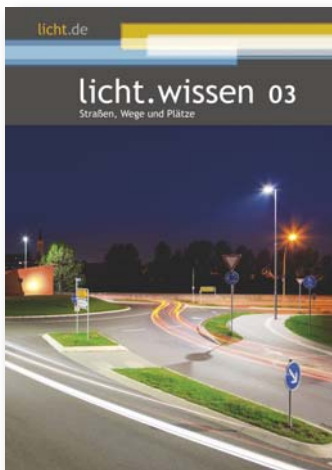

[licht.wissen 03] Best visual conditions and maximum energy efficiency: booklet 03 describes how modern street lighting ensures greater safety, reduces accident risks and contributes to attractive cityscapes.



[licht.wissen 04] Optimal office lighting promotes a sense of well-being and saves energy and maintenance costs. Booklet 4 contains 56 pages devoted to different applications and explains which standards need to be observed.



[licht.wissen 14] 60 pages of ideas for individual lighting concepts. The booklet is structured as a tour of the home. Five special chapters look at fundamental lighting issues and "Lighting Tips" are offered for each application.

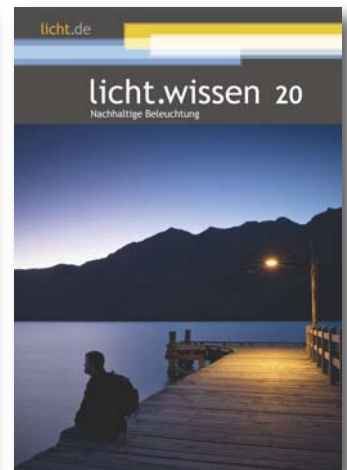

[licht.wissen 20] Efficient and comfortable: Modern lighting technology can make a major contribution to the sustainable design of our environment. Booklet 20 highlights many practical examples and provides important information on planning and construction.

licht.wissen in English – all booklets are available as PDFs, free download at [www.licht.de/en](http://www.licht.de/en)

- 01 Lighting with Artificial Light (2016)
- 02 Good Lighting for a Better Learning Environment (2012)
- 03 Roads, Paths and Squares (2014)
- 04 Office Lighting: Motivating and Efficient (2012)
- 05 Industry and Trade (2009)
- 06 Shop Lighting – Attractive and Efficient (2011)
- 07 Light as a Factor in Health (2012)
- 08 Sport and Leisure (2010)

- 09 Refurbishment in Trade, Commerce and Administration (2014)
- 10 Emergency Lighting, Safety Lighting (2016)
- 11 Good Lighting for Hotels and Restaurants (2005)
- 12 Lighting Quality with Electronics (2003)
- 13 Outdoor workplaces (2007)
- 14 Ideas for Good Lighting for the Home (2009)
- 15 Good Outdoor Lighting for the Home (2009)

- 16 City Marketing with Light (2010)
- 17 LED: The Light of the Future (2010)
- 18 Good Lighting for Museums, Galleries and Exhibitions (2016)
- 19 Impact of Light on Human Beings (2014)
- 20 Sustainable lighting (2014)

# All about light!

## Impartial information

licht.de provides information on the advantages of good lighting and offers a great deal of material on every aspect of artificial lighting and its correct usage. The information is impartial and based on current DIN standards and VDE stipulations.

## licht.wissen

Booklets 1 to 20 of the licht.wissen series provide information on the use of lighting. Themed and packed with practical examples, they explain the basics of lighting technology and present exemplary solutions. They thus facilitate cooperation with lighting and electrical specialists. The lighting information contained in all of these booklets is of a general nature.

## licht.forum

licht.forum is a compact specialist periodical focusing on topical lighting issues and trends. It is published at irregular intervals.

## www.licht.de

The industry initiative also presents its knowledge of lighting on the Internet. At www.licht.de, architects, designers, lighting engineers and end consumers have access to around 5,000 pages of practical tips, details of a host of lighting applications and up-to-the-minute information on light and lighting. An extensive database of product overviews provides a direct link to manufacturers.



[www.twitter.com/licht\\_de](http://www.twitter.com/licht_de)  
[www.twitter.com/all\\_about\\_light](http://www.twitter.com/all_about_light)



[www.facebook.com/lichtde](http://www.facebook.com/lichtde)

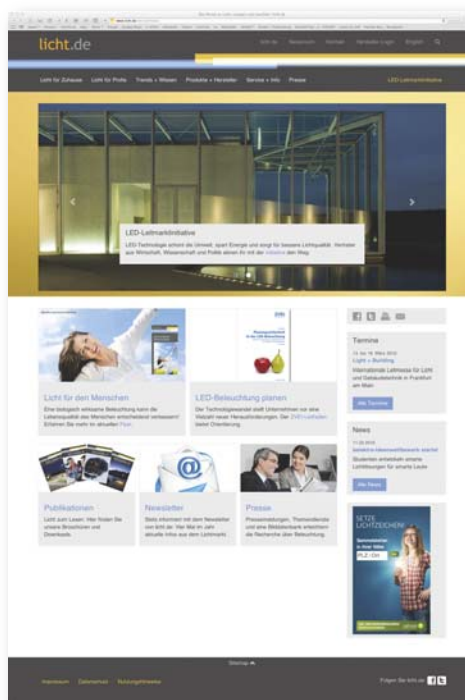

## Imprint

### Publisher

licht.de  
Fördergemeinschaft Gutes Licht  
– eine Brancheninitiative des ZVEI e.V. –  
Lyoner Straße 9, 60528 Frankfurt am Main  
Tel. 069 6302-353, Fax 069 6302-400  
licht.de@zvei.org, www.licht.de

### Editing and design

r.f.w. kommunikation, Darmstadt

ISBN no. PDF edition (english) 978-3-945220-05-4  
August 2016 (08/16/00/01V)

This booklet takes account of DIN standards and VDE stipulations valid at the time of publication, reproduced with the permission of DIN, Deutsches Institut für Normung e.V. In each case, the DIN standard applicable is the latest version, available from Beuth Verlag GmbH, Burggrafenstraße 6, 10787 Berlin.

Reprints of licht.wissen 01 in full or in part only with the permission of the publishers.

### Acknowledgements for photographs:

Numbering of photos on back page

		101
102	103	104
105	106	107

### Images

[04] fotolia.com, E. Schittenhelm; [08] fotolia.com, Piotr Wawrzyniuk.

All other photographs, illustrations and charts were made available by licht.de members or produced for licht.de.

## licht.wissen 01

Lighting with Artificial Light



licht.de

Fördergemeinschaft Gutes Licht  
Lyoner Straße 9  
60528 Frankfurt am Main  
Germany  
Tel. +49 (0)69 63 02-353  
Fax +49 (0)69 63 02-400  
licht.de@zvei.org  
www.licht.de