

# licht.wissen 16

City Marketing with Light

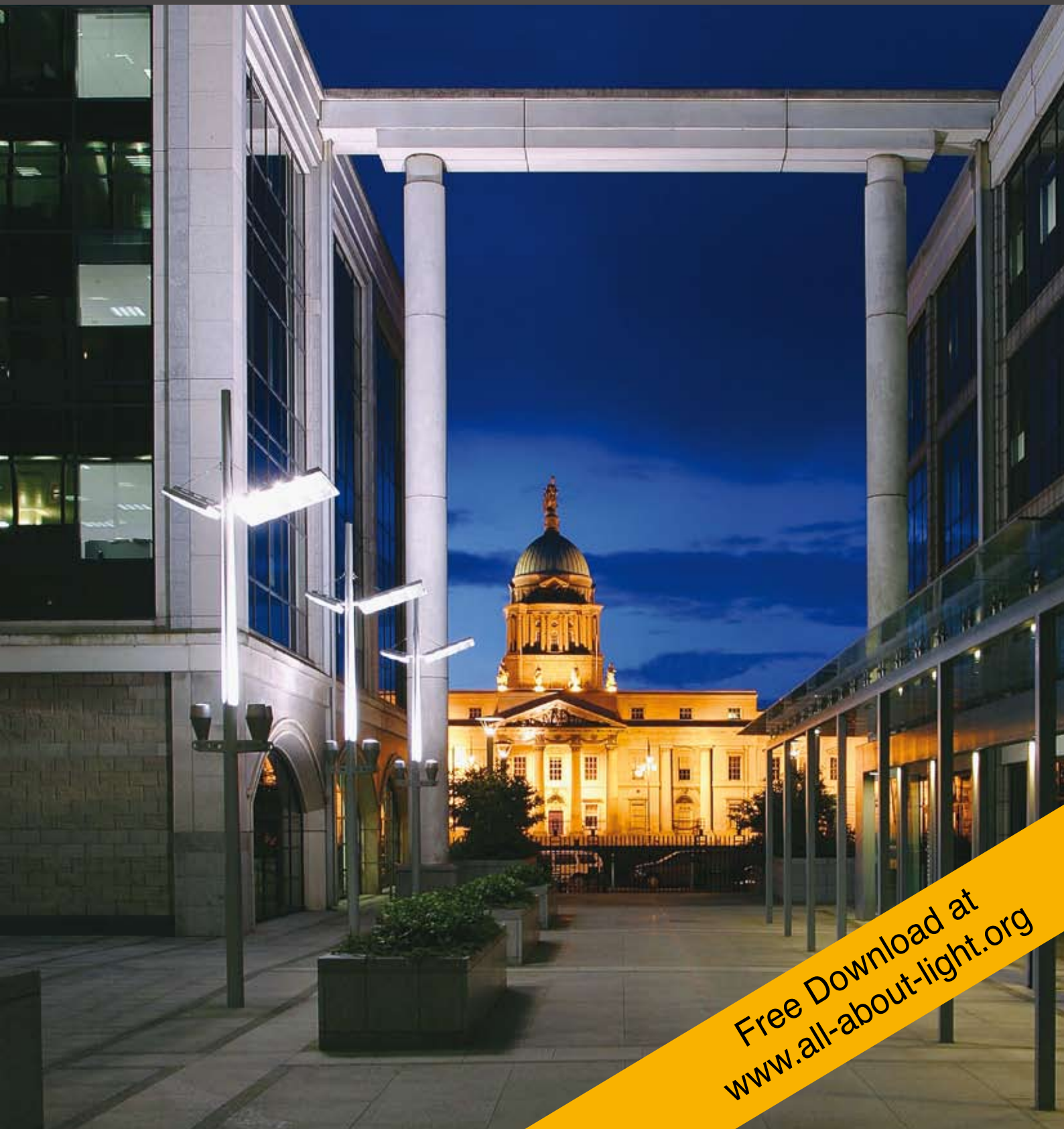

Free Download at  
[www.all-about-light.org](http://www.all-about-light.org)





# Editorial

Towns and communities are in continuous competition with each other as commercial centres, places to live and go shopping, some of them as travel and tourist destinations. City marketing has proved to be an important tool in the fight to achieve a competitive edge.

One-off actions are not effective. It is only the cumulative effect of many measures that improves the image of a community. Residents must be able to identify with where they live. And with this as the background, the appearance by night assumes ever more significance. City marketing with light offers the unique opportunity to create effects that are just not possible during the daytime and to enhance the attractiveness of public areas. The fact that people are drawn to light, is truer today than it has ever been.

It is however important that all parties involved define joint goals and follow these according to a plan. The town or city council is not the only stakeholder. Everyone who stands to benefit from an attractive looking town should be involved. This includes hotels, restaurants, retailing or even housing associations. Fixed floodlighting of public buildings, lighting up the frontages of hotels or commercial property frontages, adding light-accent to shopping malls or the illumination of public areas are just some examples. These can be added to by temporary events such as shopping and cultural evenings with special lighting effects or at advent time through spectacular Christmas illuminations. In such cases, the local authorities play a particular role. They are not just there to handle the economics but they also have to manage the events, to coordinate all those involved and all the activities into one seamless whole. It is completely legitimate to call on outside help for such events, but these tasks can usually be completed successfully using the existing, competent workforce.

Urban design with light doesn't have to fail because local authorities may be strapped for cash. Rather, it is important to integrate the ideas of all interest groups into a holistic concept. In this way, everybody contributes to each activity, in order to achieve the overall goal. Also the ongoing operation of lighting equipment these days, doesn't present those involved with insurmountable difficulties any more. Particularly in the case of accent lighting, both light planning and component development are making great advances. Targeted installations, designed to operate at close range to the buildings that use only longlife and energy-efficient light sources, significantly reduce the operating and maintenance costs.

City marketing with light accentuates the beauty of each locality, strengthens its identity and creates a positive image so that public space can take on its own personality. This increases the feel-good-factor for both residents and visitors and is shown to influence companies who may be looking to relocate. A professional and well-thought-out lighting solution built around innovative components and successful planning adds considerable value, as it reduces the strain on financial budgets over many years.

Frank Bodenhaupt  
Ludwigshafen City Council

[Title page] Different lighting colours combine to create a harmonious appearance.

[01] Schwäbisch Hall's market square, with extraordinary mood lighting.

City marketing  
Page 06



Lighting  
Master Plan  
Münster  
Page 08



Lighting  
Master Plans  
Bamberg, Bocholt  
Page 14



### Lighting special:

Detailed specialist information about relevant topics.

Energy efficiency and ErP  
Page 12



Light immissions, CO<sub>2</sub> and the environment  
Page 20



# Contents

Lighting Master Plan  
Bremen  
Page 22



Lighting planning  
basics  
Page 28



LED - Technology  
of the future  
Page 34



Publications  
Page 38

Imprint  
Page 39



Telemangement and control  
Page 26



Luminaires  
Page 32



Light sources  
Page 36





# City marketing

Towns and communities are permanently in competition with each other in terms of attracting businesses relocations and retaining purchasing power. When comparing one with another, aspects such as attractiveness, quality of life, security and image play a significant role.

[02] The peaceful, restrained lighting of the square contrasts with the lively presentation of the fountain, to create a harmonious ambience.

[03] With their differently aligned secondary optics, the projector-reflector lighting system create bright accents in the darkness. During the day however, they integrate harmoniously into the architecture of the square.

[04] The recessed ground luminaires integrate subtly into the architecture but the light that it creates, draws your gaze down the wonderful arcade passage.

[05] Light accentuates the contours of the bridge and removes the solidness from it in the darkness.

One way to make a difference is city marketing, which has established itself as a successful tool both to improve the competitiveness of the communities and to promote urban development. Here, corresponding lighting is an effective component in the mix, which is particularly suited for establishing a location's profile. A lighting concept designed to promote an image shouldn't however be restricted just to the illumination of historical buildings or churches or to the creation of powerful colour effects, as is the case in many towns. Rather, a holistic approach should be adopted that combines all the light architecture measures, resulting in a harmonious design of the town centre or urban quarter. This integrated way of looking at things creates conditions for energy-efficient lighting solutions, which also allows existing lighting infrastructures to be included.

Lighting master plans provide the mechanism for creating such primary concepts for public areas. City marketing, with light as a design aspect in the master plan, has the goal of strengthening existing potential and accentuating specific features such as historic thoroughfares, bridges, artistic objects or public squares. It is not however vital to

have prominent buildings or monuments, in order to create a pleasant atmosphere during the evening hours with targeted lighting. With a consistent light architecture, each community can provide an attractive setting for its focus point, filling it with life even outside normal business hours.

Lighting effects shouldn't fail just because funds are limited. It makes complete sense to embark on smaller projects, which should however form part of a complete concept and be designed in such a way that they can be extended at a later date. Financing can be established in part or in full through sponsorship. Public Private Partnerships (PPP) have proved to be very successful in practice.

As well as planning lighting to cover the whole area, short-term activities, so-called Light Events, also support city marketing. These "audience magnets" don't just establish an enduring, positive image of towns and communities but they often generate supraregional media reports.

## Versatile opportunities through city marketing with light

- Increases a community's competitiveness
- Gives profile to towns and communities
- Provides impulses for urban development
- Communicates a positive image
- Emphasises a town's character
- Improves the quality of a location for industry, commerce and service providers
- Promotes the retention of purchasing power and tourism
- Upgrades and adds life to town centres
- Increases attractiveness, quality of life and security for residents and visitors



# Lighting Master Plan - Münster

The lighting concept for Münster's old town was designed to add quality to the urban landscape. The holistic approach at an urban planning level also provides a solid framework for action for property owners, constructors and investors.

Alongside ecology and energy efficiency, proportionality, transferability and the quality of the overall picture are the most important criteria when it comes to creating a plan for urban development. Light is an integral component of the design concept for urban planning.

With classic, European locations, the image of the town and the level of its acceptance, are influenced by the impression it creates from three distances:

- The panorama with its perception from a distance presents a silhouette or a cityscape.
- The entrance or boundary of the town clarify the situation from nearer.
- Town centre and the central squares define the image from close up.

The entrances to towns are positioned topographically between the peripheries and the centre, between near-distance and

close up. They have the dual character of an area to stay in and an area to pass through, an opening and access, being at the same time a sort of "shared space" between the demands of providing traffic flows and those of creating an image of the town. As a "gate" or "sill" to the centre of the town they have an effect in both directions, when heading into or out of town. Routes, often acting as channels, don't always end before reaching the centre but penetrate into the town. Designed consistently, using a systematic language of light made up of colour, distribution and power rating, it is easier to understand the structure of the town plan with its axial, major and radial routes. The paired alignment of street and path lighting feeds out from the character of the portal, particularly in the areas without architectural diversity. Portal and access points upstream from the centre of the town, generate a feeling of moving through different quarters and correspond

with features that cause a reduction of pace such as pedestrian areas or speed-restricted zones. There is in part an enormous increase in urban density, which is creating higher demands for visual separation and structure. Competing luminaire systems and different mounting heights that create scattered light should be kept to a minimum, as these remove conciseness and the potential to create a composite urban landscape.

[06] The Prinzipalmarkt - historic gabled houses with an arched arcade surround the elongated, closed square. The use of a consistent language of light underlines its function as Münster's "Front parlour".

[07] The lighting concept created for Münster by Michael Batz, Hamburg's lighting planner, points up the structure of the town plan with its axial, major and radial routes.





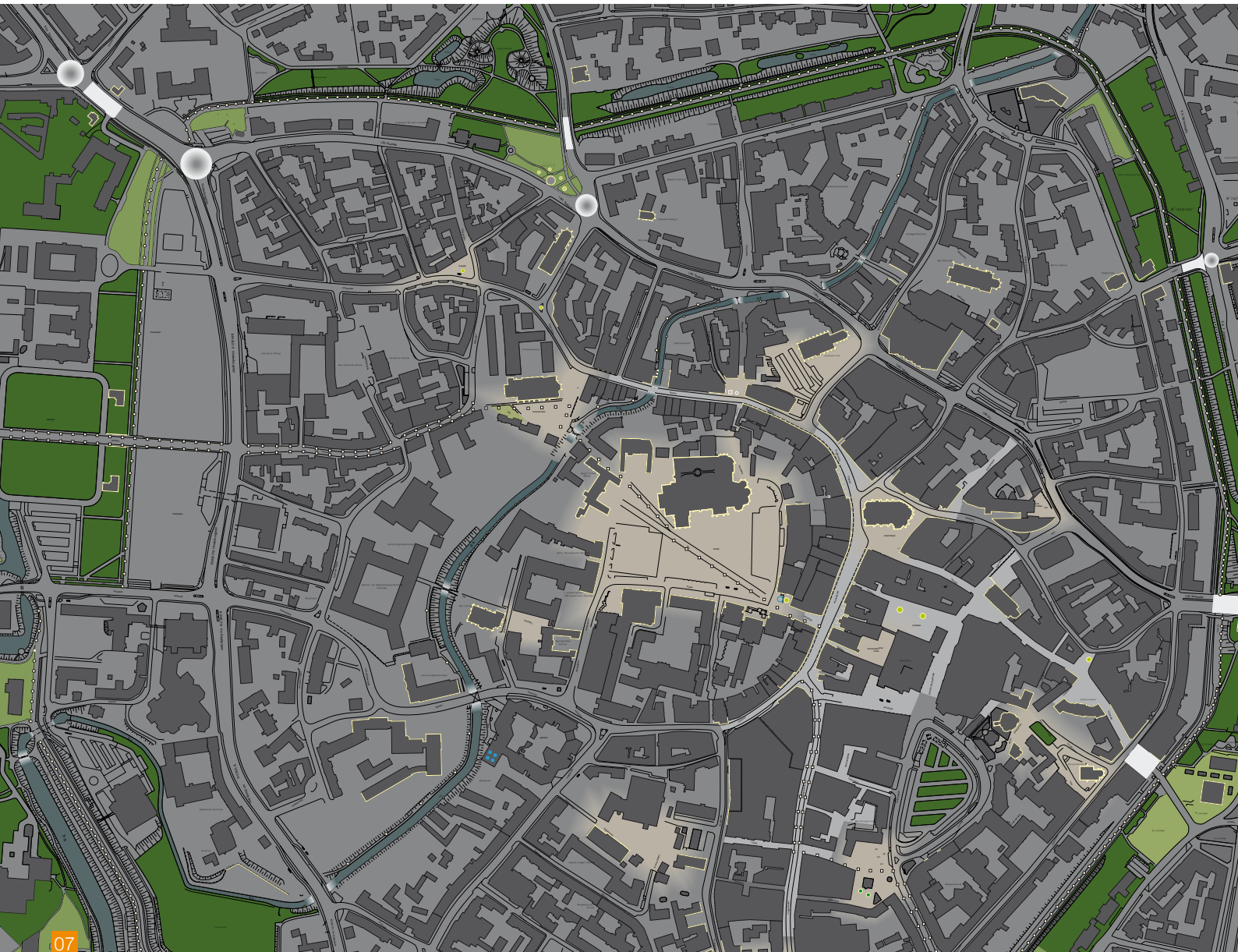

## Access to the town: Streets and paths

**Tunnel lighting [08]:** The tunnel lighting is oriented to the adaptability of the eye. The entrance calls for a higher lighting level that gradually sinks to the lower tunnel lighting level as you proceed further in. Before exiting the tunnel, the luminance is increased again. The basis for this scenario are the light strips installed on both sides that are correspondingly dimmed through the light control mechanism. Glare limitation and equality of light distribution are important criteria in guaranteeing the safety of the vehicle occupants.



**Traffic routes, traffic-calmed residential streets, footpaths and cycle tracks, squares [09,10]:** Not every location has to have the same level of illumination. Different usages place different demands on the illumination solution. The mounting height, light colour, light control, etc. must be adapted to the corresponding visibility requirements. Brightness, equality of light distribution and glare limitation, as well as optical guidance, are of relevance when it comes to providing good road lighting that promotes safety and reduces the incidence of accidents. The brighter the street, the better the driver can recognise possible obstacles. Safety is increased in a street with uniform lighting, with a minimum of shadowed and dark zones. Glare makes the safe perception and recognition of other road users more difficult. Also, drivers should be made aware, as early as possible, of changes of direction, through optical identification methods. Very wide-form light distribution provides especially uniform illumination for cycle tracks and footpaths. In this case, unlike in parks and green areas, the lighting is not just for the safety of the users of the paths, but also serves increasingly to add to the urban design. Luminaires identify paths, make their condition easier to recognise and facilitate orientation. Illumination off to the side of the paths, for instance in trees and bushes, sets attractive light accents, creates ambiances and increases the overall appeal of the environment.





## Landmarks

How does the theatre stage a king? Scarcely at all. Composure and implicitness are enough. It is mainly the royal household that surrounds him that is the subject of the staging. And the more this underlines the distance from the monarch himself, the more the hierarchy becomes evident, without having to make any excessive effort. This strategy can also be used when it comes to urban design. Buildings, sculptures or features of nature that have a "USP", can be used as landmarks, like a "king" on the urban stage. It distances itself from its environment through its height, as with a tower or a church, its shape and size, as with a bridge, its position and function as with a gate or its particular idiosyncrasy that can come through art or through being the stuff of legend. Landmarks are loved and sought after as these features represent the spirit of a town, its uniqueness and its distinctiveness. They are often referred to as being the heart of the town and they are always the subject of choice for picture postcards.

The "lighthouse" function of landmarks has always had a large significance when it comes to lighting design. The advance in lighting technology means that illumination that was previously done from a distance, from surrounding roofs or from columns, has now been replaced by lighting that is installed in close proximity to the object using smaller, targeted applications. The lower the competing ambient light, the easier it is to create an impressive image of the object, often using very low levels of illuminance. There is however no way round a holistic consideration of the environment, particularly with such individual elements.

What is important for the lighting concept is not the surfaces of the landmark but more especially the gestures and shape, its contours and lines. With taller constructions, it is advisable to use a multi-step approach with addressed light sources, in order to pick out architectural features. This shouldn't result in a single whole made up of the individual effects. The integral concept of the construction must be supported and highlighted. In the case of towers, particularly church towers, it may be possible to illuminate from inside, i.e. through the dormer windows, in order to accentuate the fine details.

Lighting effects and colours can only be used temporarily with landmarks, if at all. A particularly spectacular example of this are the 20,000 flashlights on the Eiffel Tower in Paris, that only sparkle at the top of each hour.

Dominant features that mould the shape of the town and provide highlights are suitable as design subjects, including spectacular or unique constructions, local features or large trees. Traditionally, historical buildings, fountains and bridges belong to both the functional and atmospheric stock of "entrances" or "foyers" and are still very popular today.

Significant for achieving a coherent perception are the lines of sight and the limits of sight, the edges of groups of buildings and the accentuation of markers along the radial routes. In this way, town entrances are an indicator of the quality and standard of the town's lighting. Here you can see examples of how elementary factors, i.e. anti-glare, low mounting heights, light colour arrangement and light addressing have been implemented in a structured way.

The outskirts of towns such as green belt or park areas, form contrasting zones of quiet

and reflection. Within the ring structure, the same type of light design such as type of luminaire, light colour and luminance should be ensured. Glare reduced path lighting is enhanced by the highlighting of impressive tree groupings or single trees picked out as natural landmarks.

[11] Because of the minimal ambient lighting, very low illuminance levels are enough to create an impressive image of the late gothic town and market church of St. Lamberti.

[12] The castle in Münster, today the main university building, can be viewed as part of the "atmospheric stock", where lighting clearly picks out the features of the baroque three-wing building, constructed of bricks and light-coloured sandstone.



# Lighting special: Energy efficiency and ErP

Looking to the future and energy efficiency are topics that are influencing local authorities these days. For this reason, lighting concepts are called for that are based on innovative light sources and efficient luminaires, integrated into intelligent control systems.

Towns and communities make a significant contribution to climate protection as energy efficiency has become a central aspect with city marketing with light. Authorities' lighting concepts are increasingly measured according to how they address the potential for the reduction of energy consumption. This isn't just a question of reducing the level of the lighting or abdication of light quality. Much more it is to do with harmonising the needs of the people in terms of visual comfort and safety with ecological and economic demands. Innovative lighting solutions in combination with intelligent control systems are the answer to this delicate balancing act.

Wide-ranging benefits result from such lighting concepts:

- Shaping the profile of the communities through attractive light designs
- Improved light quality for the good of the citizens and for increased safety
- An image-plus through commitment to sustainable energy-efficient products
- Reducing the load on the environment through significantly reduced energy consumption and reduction of CO<sub>2</sub> emissions

Such energy saving measures are not just brought about because of a desire to protect the climate or because of statutory guidelines. Also spiralling energy prices and reduced budgetary resources are forcing towns and communities to act. Energy consumption can be reduced by up to 80% with new lighting technologies while at the same time delivering significantly increased light quality. Thus, the eco-design guidelines also have relevance for lighting in the public domain, as in the last years, road lighting has developed to become a design element in the urban space. This has increased the number of lighting points and the energy requirements. In addition, existing equipment is based on outdated, inefficient technology both in terms of the deployed operating devices and the lamps themselves. The

EU regulation 245/2009 will have a large effect in this area and clear the way for energy efficiency.

## Energy-saving potential - road lighting

Communities can reduce their energy consumption by up to 70% by deploying new road lighting equipment. These possible savings result from an improvement in the lamps, operating devices and luminaires. LED lights can even make savings of up to 80% possible. However, the suitable photometric equivalent is not yet available for each application. But, through the progress that is being made in LED technology, further application areas will soon be catered for.

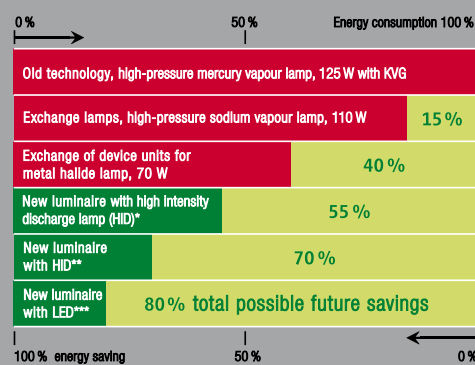

\* High-pressure sodium vapour lamp or metal halide lamp

\*\* High-pressure sodium vapour lamp or metal halide lamp with control system and 50% power for 2,000 hours

\*\*\* With control system and 50% power for 2,000 hours

## Statutory requirements

Almost 20% of global power consumption is used for lighting. And as a result, introducing energy-efficiency into the lighting market has become a high priority for the European Union. The principal instrument of EU legislation in this area is the EU framework directive 2009/125/EU (ErP), introduced on 20th November 2009, which, as the successor to the original eco-design Guideline 2005/32/EGU (EuP), focuses on the eco-design of "energy consumption relevant" products. The minimum requirements for non-directional

domestic lamps, in particular light bulbs, halogen bulbs and compact fluorescent lamps, are defined by the EU Directive 244/2009, the first part of which came into force on 1st September 2009.

This was then followed on 13th April 2010 by the first stage of the EU Directive 245/2009 with relevance for the service industry, with the regimentation in the tertiary sector. This defines the demands for energy-efficiency and operating characteristics as well as the quality of products that are principally used in commercial, industrial and street lighting. This includes fluorescent lamps, high intensity discharge lamps together with the corresponding ballasts and luminaires. Inefficient lamps and ballasts that do not conform with the demands may no longer be sold and are being removed step-by-step from the market. As a result, there is an increasing compulsion on all users to change over to energy-efficient technologies.

### Energy efficiency and freedom of design.

Recommended economic alternatives for use in the public domain are metal halide lamps with excellent colour reproduction, high-pressure sodium vapour lamps with a long working life as well as compact fluorescent lamps. In addition, LED technology is increasingly establishing its place in exterior lighting. The semi-conductor light source scores through low energy consumption, high efficiency, very good colour reproduction, UV-free light and a long working life, coupled with practically no maintenance requirements. At the same time, because of their compact construction and controllable lighting colours, LEDs offer enormous design options for city marketing. The spectrum ranges from frontage illumination to installation in floors, stairs or hand rails to provide guidance, right up to special effect lighting, even under water. But it is only with the deployment of intelligent lighting control systems that the full energy saving potential of public lighting equipment can be realised. These can be used to program usage-dependent lighting scenarios and single light points can

be individually controlled. The so-called telemanagement offers for example, the pre-requirements for the sensor-controlled dimming of road lighting depending on time of day, weather conditions and weight of traffic or the switching off of light points.

### Efficiency role modelling

At the end of the day, towns and communities have a role model function to fulfil. The commitment in terms of energy efficiency and CO<sub>2</sub> reductions, acts as an impulse for residents, commerce and industry to also be proactive in protecting the environment and in saving energy. This also adds to the positive image of a community.

[13] With the aim of energy efficiency, the motorway bridge was equipped with LED lights as an architectural design element.



# Bamberg and Bocholt lighting master plans

In Central Europe, because in part of changes in leisure time activities and a Mediterranean influence, life in the public domain has taken on an extra importance. As a result, there hasn't just been an increase in the quality expected of the locations, also after dark, but they are attracting the attention of the population more and more.

Criteria such as individuality, inter-town competitiveness and also environmental protection call for a differentiated redevelopment of our towns and cities by night. Just like the guiding concept that "Light creates quality of life", these complex demands also form part of the lighting master plan. The planning-based approach has been developed over the last two decades. The procedure, from the creation of diverse planning levels through the master plan and on to the implementation itself, is also well developed and established.

Often designated one-dimensionally as an instrument of urban planning, the lighting master plan covers much more than just architectural lighting, light as art and design of luminaires. Increasingly, it is in the cross-hairs of the demands for lighting performance, urban design and town usage and commerce. It is not just the quality of public lighting that has to be taken into account but also private and commercial illumination measures such as shop window design or illuminated advertisements. All of this has to be integrated into a spatial, nighttime concept. Lighting planning is therefore, an

integrated component in the development of a contemporary urban landscape.

## Bamberg's lighting design

As the first project from the lighting master plan that had been drawn up for the whole town, Bamberg upgraded the oldest part of the town. The specifications and guidelines in the plan could be tested and further developed through the renovation of Sandstraße, which located below the cathedral square, runs between the cathedral and the station. Conversion to a pedestrian zone addressed the concerns of the many restaurants in the area and the enclosed architectural ensemble. In order not to clutter the appearance of the narrow streets with forests of vertical street furniture, luminaires were suspended between the buildings, many of which dated from the middle ages. The atmosphere was enhanced by the light from the metal halide lamps with 2.800 K colour temperature. The lighting stands out in terms of its efficiency through the use of low power ratings (45 W and 60 W ) but at the same time high luminous flux. The typical middle-age townhouse character of the buildings was underlined

by applying specific lighting accents. The line of the curve of the street was intensified by highlighting the arch of the entry gates. LED recessed ground luminaires with 3 W power and a neutral-white colour provided the necessary contrast to the warm-white functional lighting. The floodlighting of the main building at the entrance to the street provides a visible boundary. The maintenance of the quality of this atmospheric light scene started once the building work was completed at the end of 2008.

[14] Spatial structures with road axes, link roads, rises and falls in the riverside path, footpaths on the hill and the former moat.

[15-16] Boundaries for the narrow streets are marked by buildings.

[17-18] In the curved street of houses, the facades along the outer edge are highlighted.

[19, 21] Sandstraße with accentuated doorway arches: Luminaires suspended between the buildings provide the functional lighting.

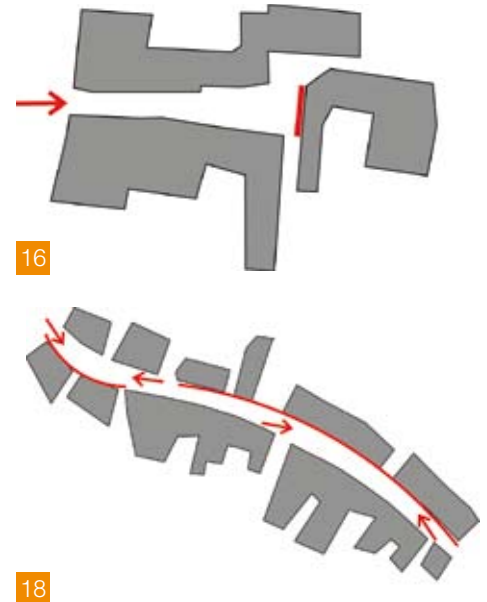
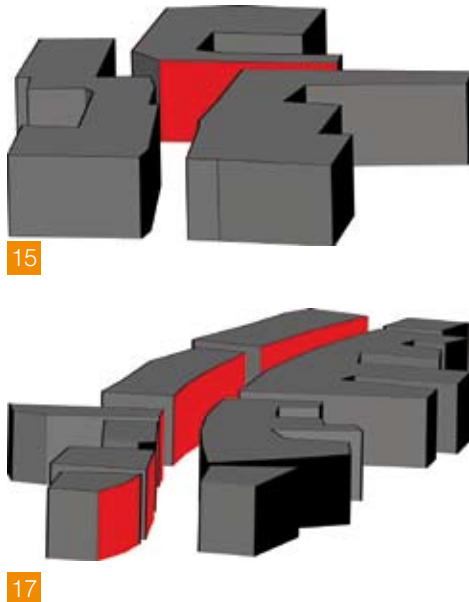



19



20

## Pedestrian zones

Increasing sales by lighting design [20]: The illumination of pedestrian zones has proved to be an important element of urban design. The decorative aspect counts both in the daytime and at night: During the day pole lights, columns or ground-level lighting integrate harmoniously into the urban scene. At night, the attractiveness is increased by illuminating building facades, arcades or fountains. The quality of the lighting, particularly the colour reproduction of the lamps plays a very important role. Attractively designed intra-urban areas have a sales increasing effect for shops and restaurants. Additionally, lighting also fulfils a protective function: Obstacles are easier to see and security is significantly improved.



21



22



23

24

[22] Bamberg Lighting Master Plan.

[23] Representation of the sequence of road connections and the widening of squares.

[24] The main thoroughfare gives a rhythm to listed buildings and attractive facades.



25



## Squares in Bamberg's Lighting Master Plan

Situated in the middle of Bamberg's most important thoroughfare linking the station and the cathedral, Maximilian Square stands out because of the well-balanced proportion of its surface area to the buildings that surround it. Particularly the buildings on the long sides, namely the town hall, Krackhardthaus and department store dominate the space and give the square its prestigious look.

The square plays a central role in the lighting master plan drawn up by Uwe Knappschneider from Wuppertal, because the renovation of the square and the creation of the plan happened at the same time. This pilot project awakened the interest of both the residents and politicians and prompted them to get involved with the lighting design at an early stage. At the same time as achieving spatial quality, the concept

envisions lighting designed to highlight the boundaries of spaces. From a design standpoint, the luminaires themselves blend into the background. Because of their slender shapes, they have to a large extent a transparent effect and illuminate the main zones along the edges of the square with a brilliant light without leaving the actual square in darkness. Spotlights built into the columns provide added brightness to the facade of the town hall through a soft, areal general light. Highpoints of the building and specific architectural details however, are accentuated by additional spots or recessed ground luminaires.

To complement the design of the more than 10,000 m<sup>2</sup> area, the adjoining streets are not directly integrated into the square's lighting but are identified through the corresponding, specific road lighting. The uniform design language of these luminaires and the square's columns produce a harmoni-

ous appearance. The row of columns in the Hauptwachstraße come from the same program, but the mounting heights are set lower and they also provide illumination for the buildings.

The peripheral located, solitary fountain is the only thing to catch your eye in the expanse of the square. Recessed ground luminaires illuminate King Max I. Joseph and accentuate the important religious and secular dignitaries who surround him. With the redesign that was completed in the spring of 2006, the square offers a flexible location for events and markets or simply a generously proportioned urban space.

[25] The illuminated retail signage is discretely integrated into the overall picture of the facade and the square's lateral boundary.

[26] Recessed ground luminaires accentuate the fountain's sculptures.

## Squares

Life on the square [25-27]: Frequently encircled by restaurants, bars, cinemas or businesses, both residents and tourists are happy to spend their time here, just watching the world go by and relaxing. For this reason, the lighting of squares shouldn't just provide the passers-by with a feeling of security. Much more, they should create an atmosphere to welcome and attract. As reflective surfaces, illuminated facades provide an excellent backdrop. Design-oriented luminaires can accentuate the architecture and adding highlights to a fountain or a monument, rounds off the attractive complete picture. In order to guarantee security, an average illuminance of 7.5 lux is recommended for squares where less people are to be found. In the case of squares that attract more visitors, this should be increased to 10 or 15 lux. The subject of environmental protection must be taken into account. Here, it is principally a question of minimising light pollution by avoiding scattered light, the deployment of energy-efficient and environmentally sound lamps and the selection of light colours that don't impact negatively on nocturnal insects or animals.

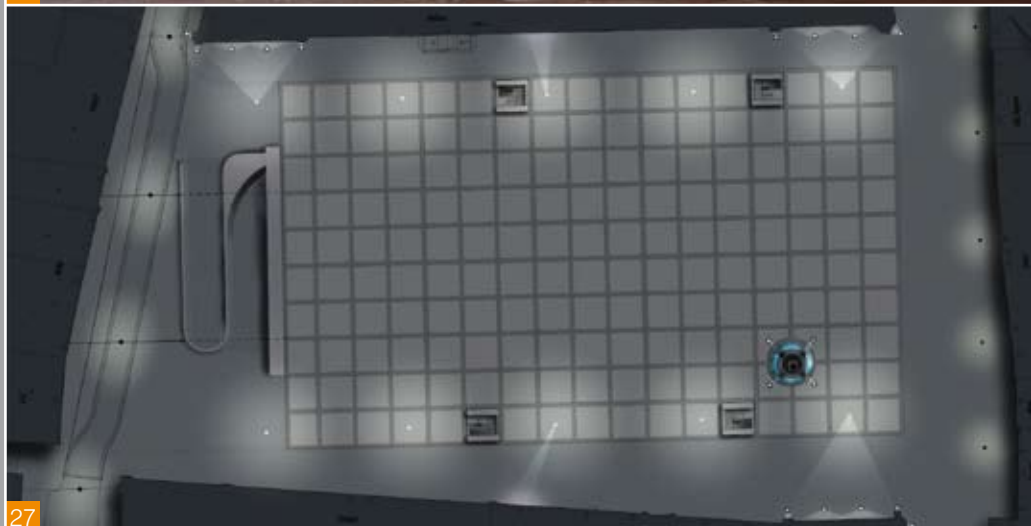



## Bocholt plays with light

The goal of urban development measures in Bocholt was to improve the experience of being in the southern part of the city centre. To this end, the surroundings and waters of the river Aa were again to provide a haven of green, which should also be showcased accordingly after dark. This produced one of the guiding themes of Uwe Knappschneider's lighting master plan.

One area of conflict concerned the design of the banks. In the west part, the banks of the river are supported by steel piling or stone retaining walls. The east side, on the other hand, are principally more semi-natural banks, bordering onto areas of green.

The lighting should reflect the different characters presented by the various bank situations. Soft lighting, reminiscent of plant shapes, was applied to the hard-edged

banks. The softer areas of bank were given sharp contours through "hard" light projections. The willow trees that are found all along the banks of the Aa, provided a linking element. Lighting from below, provided by high-pressure sodium vapour lamps, bathed them in a golden light, which provided the right effects while at the same time looking after the interests of the insect life.

The interplay between the light colours and the contrasts is what really catches the observer's attention. Particularly the view across the linear green corridor provided by the river, towards the impressive architectural features of the city, doesn't just give a feeling of spatial depth but also one of subjective security.

[28] View over the river towards the Sankt Georg church in Bocholt: The willows are illuminated in yellow by high-pressure sodium vapour lamps.

[29] Luminescent floating spots of soft light act as the welcome antithesis to the hard architectural lines on the bank.

[30] The weir, highlighted in cool blue, provides a strong colour contrast to the trees.

[31] Layout plan of Bocholt showing the significant structures from an urban planning viewpoint.



## Parks and green spaces

Areas to rest [32]: In contrast to squares, parks and green spaces act as oases of calm, as "green lungs" for residents and tourists. The principal purpose of the lighting here is to guarantee the safety of the passers-by. Column or bollard luminaires delineate the routes of the paths, add depth to the space and offer better orientation in the dark. For this reason, luminaires are deployed that have wide-angle or even rotationally symmetrical emission characteristics, to provide a pleasant atmosphere for walkers, joggers or cyclists, but also to prevent criminal activities. It is also easier to identify the nature of the surface, obstacles and changes in level with lighting that balances out the areas of light and shadow. There is no standard for the illumination of parks and green spaces, which have to meet both functional and decorative demands. Recessed ground luminaires provides appealing and colourful accents for solitary trees. The attractiveness of the area can be increased by illumination that provide the correct accentuation of sculptures or monuments.

# Lighting special: Light immissions, CO<sub>2</sub> and the environment

"Who has stolen the Milky Way?" Too much light outdoors doesn't just result in high energy consumption. It also impacts on the environment. This can mean, for example, that you can no longer see the stars in the night sky. Lighting solutions that use efficient light sources, high-efficiency luminaires, with low levels of scattered light and intelligent control systems are the future.

According to the German Federal Emission Control Act, light immissions are considered to have damaging effects on the environment if, as a result of their type, size and duration, they cause risk, significant disadvantages or significant stresses for the general public. The so-called light pollution that can be seen particularly clearly above large towns and urban conurbations, caused by street lighting, illuminated advertising and floodlighting or Skybeamers, is having a range of effects on the natural world. Artificial lighting has shifted the day-night rhythm of many people. The growth cycles of plants is influenced by the existence of an artificially illuminated environment. You scarcely see nocturnal animals such as owls or fireflies any more. And astronomical activities that call for high levels of darkness are severely restricted.

## Efficient outdoor lighting control

Scattered light is largely responsible for the brightening of the night sky. Professional planning can mitigate against this while at the same time reducing energy consumption. In this case, the light intensity and brightness that are needed for compliant outdoor lighting are defined. It is also necessary to select suitable lenses for targeted lighting control. Switch-on times controlled on a need basis, minimise light immissions and also increase the energy-efficiency of lighting systems in public areas. And it is not just the environment that benefits but also society, through an improved quality of life.

[a] Conventional globe lights with bare lamp: Some 50% scatter loss through the illumination of the night sky; around 30% scatter loss through the illumination of non-relevant areas or facades; utilised luminous flux, approximately 20%.

[b] Conventional road lighting with bare, screened lamp: Some 30% scatter loss through the illumination of the night sky; around 30% scatter loss through the illumination of non-relevant areas or facades; utilised luminous flux, approximately 40%.

[c] Conventional technical road lighting with reflector: Some 8% scatter loss through the illumination of the night sky; around 22% scatter loss through the illumination of non-relevant areas or facades; utilised luminous flux, approximately 70%.

[d] Modern, column luminaires: Some 2% scatter loss through the illumination of the night sky; around 20% scatter loss through the illumination of non-relevant areas or facades; utilised luminous flux, approximately 78%.

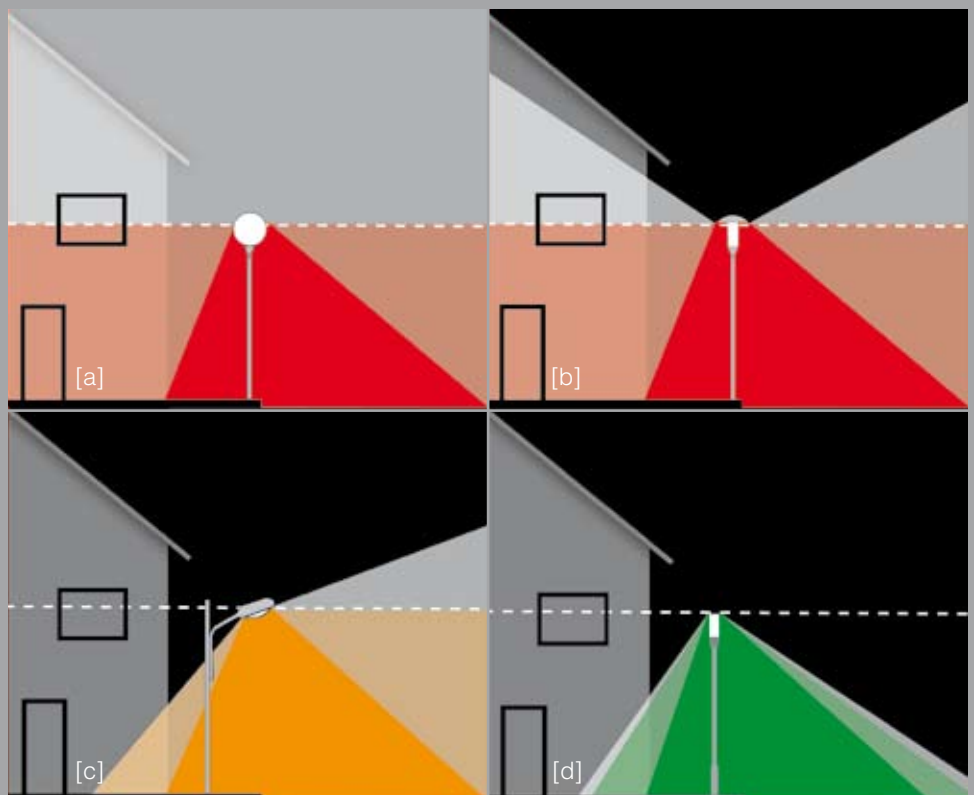



## CO<sub>2</sub> emissions and environmental protection

The reduction of CO<sub>2</sub> emissions to protect the environment can be achieved by generating power from renewable sources and by reducing energy consumption. This is also true with lighting, because in industrial companies, on average 20% of energy consumption is used on lighting, in shopping malls this goes up to 30% and in office buildings, it is about 40%. Energy consumption can be significantly reduced by the use of new lighting systems.

When considering the complete life cycle of a lamp, it is the use of the light that impacts to the greatest extent on the energy balance and therefore on the environment by up a factor of up to 90%, depending on the deployed light source. Manufacturing, transport or disposal only play a minor role. Nevertheless, when developing new lighting, as well as complying with RoHS requirements, consideration must be given to environmentally-sound and easy disposal, in order to facilitate the disassembly and recycling of the different components and materials.

## Lighting and insects

Artificial lights act as a lure to insects. This brings the risk that the natural lifecycle of nocturnal animals, whose way of life is adapted to the dark, can be destroyed. However, the use of lighting with mainly yellow and orange components, reduces the pull on insects, as their eyes have a different brightness sensitivity than human eyes. It is the case for most nocturnal insects that they perceive the spectral composition and the brightness of the light generated by fluorescent lights and high-pressure mercury vapour lamps more

strongly. Even the weak light given off by the moon, which insects probably use for orientation, is sensed by them as being significantly brighter. On the other hand, the light of high-pressure sodium vapour lamps appears for them to be darker than it does for humans, as most insects are almost insensitive to orange and red spectral components. Because of the lack of UV emissions, LED light can also be designated as being insect-friendly.

## RoHS

The European Union Directive 2002/95/EG on the restriction of the use of certain hazardous substances (RoHS) in electrical and electronic products, restricts the use of lead, mercury, cadmium, hexavalent chromium and certain flame retardants, in order to protect the environment. As with the WEEE Guideline, the RoHS Directive has also been applied to German statute through the act governing the "sale, return and environmentally-sound disposal of electrical and electronic equipment".

## WEEE

The "Waste Electrical and Electronic Equipment" (WEEE) Directive 2002/96/EU, together with the 2003/118/EU Directive deals with the handling of waste electrical and electronic equipment. These call for the implementation of a concept of extended responsibility on the part of the manufacturer, who is obliged to finance the collection, storage, transport, reclamation, recycling and correct disposal of his products. In this connection, manufacturers are obliged to monitor and limit the effects their activities can have on the environment. To this end, the introduction of an environment management sys-

tem, certificated in accordance with ISO 14001:2004, is a suitable step to take.

## Greenlight Programme

The Greenlight Programme was drawn up by the European Commission Directorate General Energy & Transport. It points up private and public organisations that have significantly reduced the energy consumption of illumination systems, by the introduction of measures to increase energy-efficiency. Participation in the programme is voluntary. The partners commit to modernise their existing lighting and to improve the quality of the lighting. The deployment of the latest technology must become the norm and lead to a reduction in overall power consumption for lighting by at least 30%.

[33] Metal halide lamps of lower power ratings offer sufficient light, in order to guarantee orientation and safety as well as creating an attractive urban landscape.

# Lighting Master Plan Bremen

The lighting master plan emphasises the architectural qualities of the Bremen city centre, defines focus points, provides a structure and creates atmosphere.

The face of a city changes during the course of the 24 hours of a day: So for instance, during the day the warm, rosy autumn sun makes the facades almost glow, clear winter air gives the buildings a more distinctive appearance than damp, foggy air that produces grey, shadowy shapes. At night, it is a different story. Windows emit light to the outside, public areas expand into the buildings, illuminated advertisements compete with each other, street and footpath lighting gives structure and orientation. The lighting master plan from Ulrike Brandt Licht of Hamburg, underlines the qualities of the city centre of Bremen around the town hall, the cathedral and the Church of Our Lady, defines focus points, provides a structure and creates atmosphere. Bremen presents itself as a

role model with the phased implementation of a master plan. The awareness of light needed for this work results from the many years of collaboration between the Senator for Construction, Environment and Traffic and the Highways and Traffic Office. This has even led to the development of the city's own light culture.

## Focussing on the quick overview

The figure ground plan offers a night-time, bird's eye view of the planning area. Light points indicate the positions of the luminaires and bright surfaces point up streets or squares that are illuminated by surface radiating sources. Facades that should be particularly emphasised are highlighted in red. This type of visualisation lets you iden-

tify the principles of the master plan. Additionally, the relationships of the roads and the concentration of historically impressive facades in the city centre are made clear.

## Demonstrative practical test

The illumination tests are an important component of any lighting planning as they clearly demonstrate the actual effect of the proposed lighting, at the point of use. Comparisons can also be made between lamps of different light colours and power ratings. This "road testing" is particularly important for the constructor as it makes it easier to establish an informed opinion. To this end, an electrical installation company installs some of the proposed luminaires on site. Often, this improvisation calls for some complicated and risky mounting, as the lights cannot be fixed permanently to the building facades.



[34] The figure ground plan shows a night-time overview of the planned lighting measures.

[35] As the focus of the city, the town hall is lit in a correspondingly expressive way, to make it stand out from the buildings that surround it.

[36] Recessed ground luminaires light up the golden inscriptions on the columns with their warm light colour. The entrance from Martinstraße to Böttcherstraße can be clearly identified.

[37] The arcade arches are flooded with warm-white light from wide-angle uplights.



35



36



37



[38] The Bremen Town Musicians stand near the town hall, at the entrance to the Schoppensteel. They are particularly important as a tourist attraction and call for a special staging. One spotlight mounted on the town hall facade illuminates the sculpture at a steep angle from one side. The result when viewed from the rear is an impressive silhouette, with a shadow of the Bremen Town Musicians being projected onto the cobbles.

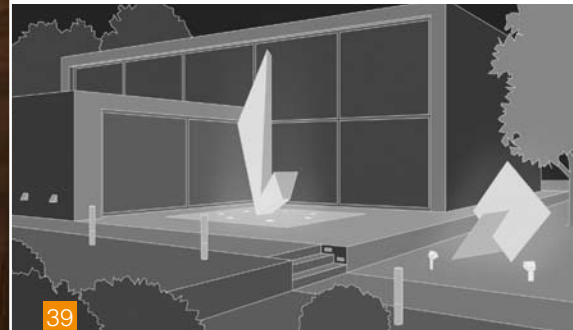

## Monuments and objects

Illumination of monuments and objects [39]:

Decisive for the recognition of monuments at a distance, is the contrast in luminance to its environment. Because they form the end point to axes on roads, squares and in parks or are themselves the focus, differentiated lighting is required. Tall, slender monuments can be highlighted with powerful, spot-beaming floodlights. In order to keep light immissions to a minimum, these have to be positioned and aligned very accurately. In such cases, the illuminance has to be adapted to the size of the exhibit, in order to maintain a balance between the object and the light. Recessed ground luminaires can be integrated subtly into the architecture of monuments, illuminating them from below and accentuating the details very effectively.



## Facades in all their detail

As vertical surfaces, building facades contribute significantly to the spatial effect of squares. Two lighting types complement each other in Bremen's city centre: The wide-angle, calm, long-distance illumination from a lighting column or from a light mounted on another building and the sectioned, accentuated illumination of the building's nooks and crannies. This combination gives a generous appearance to the facades, which is at the same three-dimensional and structured.

## The town hall as the focus

The starting point for all the thought processes concerning lighting was the historical town hall, which, in line with its significance as the city's focus and as a UNESCO World Heritage Site, calls for expressive staging. Its facades that face the marketplace, are decorated with different,

architectural elements: arcades topped with balconies, a central projecting risalit, gables and extensive roof surfaces. Three complementary lighting tools are used to pick out and accentuate the fine details:

- Wide-angle lighting from a distance creates a calm facade that is not overly three-dimensional.
- Lighting installed closer to the building brings the three-dimensionality, which however on its own would create effects that were too dramatic.
- The lighting from the windows adds life to the facades and establishes an interesting juxtaposition between the inside and the outside.

This theatre in lights is repeated on all four sides of the building, as the town hall does not just add spatial distinction to the market place. Although the illumination as seen from the market place is the most detailed, the view from Schoppensteel side is in the direction of

Obernstraße. The gable end that looks out on the market place is bathed in distinctive lighting that is visible over a long distance. By a reduction in the brightness, the rest of the facade fits in with the narrow space between the Church of Our Lady and the town hall. The town hall signals its presence to the large area of the cathedral square and to the cathedral itself through the illumination of the roof that runs around the building. People are also drawn to the building by the structured light emanating from the windows amidst the extensive, soft facade illumination.

[41] Light is used to emphasise the filigree metal balustrade and the sculpture in the wall niche.



## Fountains and light sculptures

Fountains [40]: The use of a small number of recessed ground luminaires has a restrained effect, but they pick out the plasticity of the outline or of the sculptures of modern or historical fountain constructions very expressively. LEDs or fibre-optic lighting systems are particularly suitable if you want to create an impressive interplay between light and colour, by using illumination to define accents in the water or around the fountains. Wall-mounted fountains can be high-lighted very sensitively using white light from filigree lighting.

Light sculptures [41]: Light sculptures are as rich in their variety as the different approaches of the artists who create them. Coloured or white light both have an equal role to play. Such light objects decorate buildings or they can stand alone as an "eye catcher".



# Lighting special: Telemangement and control

Energy efficiency is the hot topic that runs through all areas of lighting applications, including of course exterior lighting. Intelligent telemangement systems ensure energy-efficient operation combined with safety on the streets.

Energy efficiency and the resultant reduction in CO<sub>2</sub> emissions are aspects that are also increasing in importance when it comes to road lighting. Added to this, there is the goal of all local authorities to reduce costs. And that in the face of continually rising energy prices. An effective tool here is telemangement as the control system for exterior lighting. In this case, the "power line" process is used for data transmission. The signals are transmitted through the normal power supply network.

monitoring of all connected lamps, operating units and luminaires, thereby simplifying maintenance and reducing the costs. At the same time, safety is increased on the streets and paths and even light immissions are reduced, because of the use of need-based lighting.

## Telemangement

Telemangement systems for exterior lighting mean usage based on need, resulting in considerable potential for energy saving, because each individual light point can be switched off, on or dimmed at any time. Additionally, information about the operational status, energy consumption and technical failures is collected and stored in a database, with exact time and positional data. This supports the organisation that

[42] Typically, a lighting management system is made up of the following components:

- 1 Luminaire controller
- 2 Ballasts
- 3 Powerline transmission
- 4 Communication module
- 5 Transmission path to the server
- 6 Central server with user software

Telemangement systems allow towns and cities of all sizes to establish intelligent solutions for exterior lighting, which react in a fully flexible way to the weight of traffic resulting in a more efficient use of energy and a minimising of energy costs. A further benefit is, that thanks to the bi-directional communication, there can a permanent

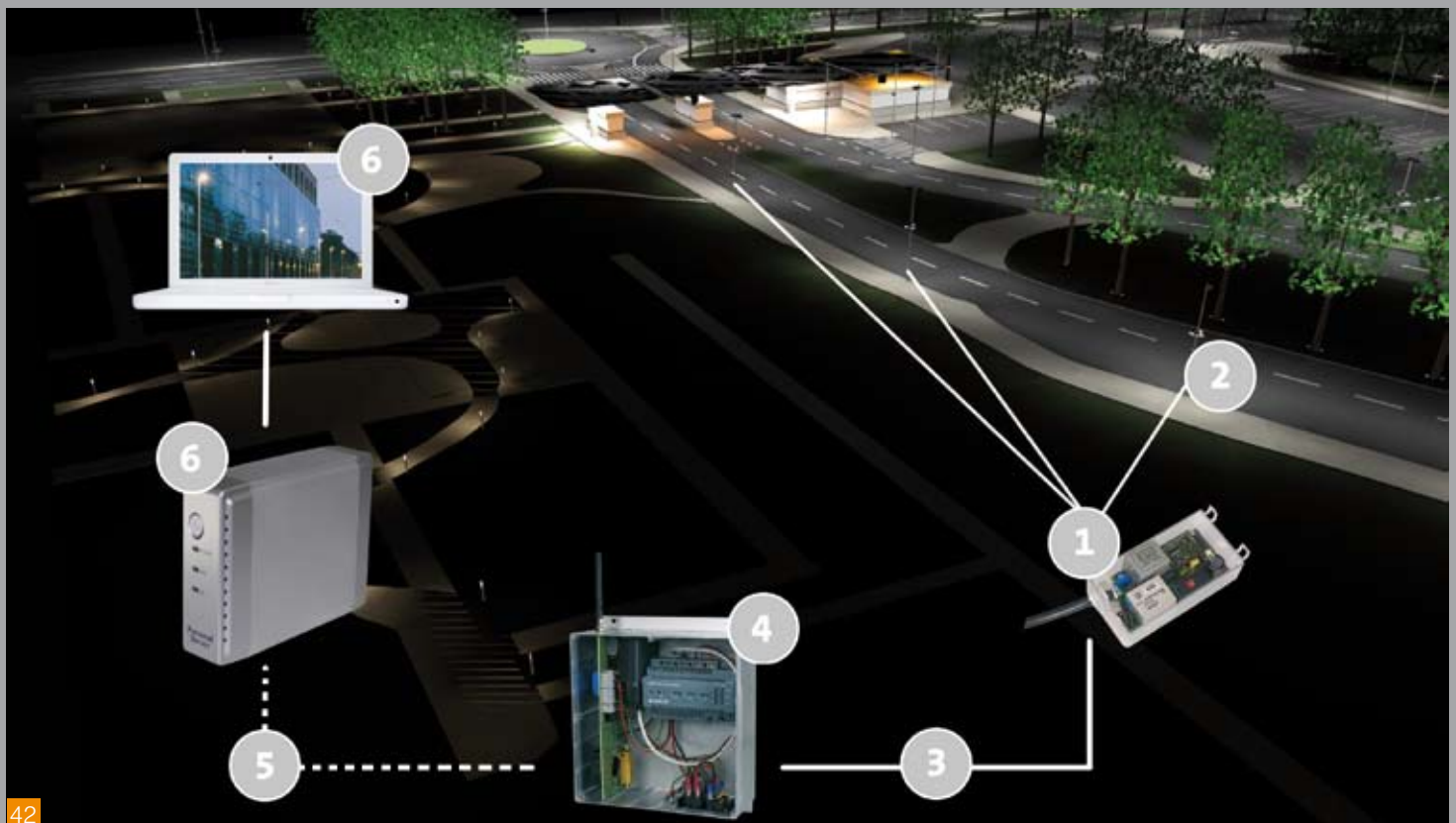

is operating the road lighting systems, on the one hand to create a planned maintenance concept and on the other hand, by guaranteeing safety on the streets by delivering a suitable level of lighting. This doesn't just lower operating costs. It also improves reliability.

An energy-efficient operation, controlled through telemanagement, contributes to the reduction of CO<sub>2</sub> and light immissions, which is an important aspect at a time of increasing environmental awareness. Just as important is the possibility to adjust the lighting level to meet the current requirements, thereby increasing traffic safety. This means, for example, increased light when there is more traffic or if there is an accident or during inclement weather and a lower lighting level at times of reduced traffic flows. This results in energy savings without reducing safety or comfort and keeps up with the trend of providing attractive inner city areas. Just the reduction of brightness levels at times of reduced traffic flows alone, can reduce energy consumption by 30 or 40%.

In order to guarantee that the required illuminance is maintained over the whole life cycle, a maintenance factor is applied at the planning stage that balances out the decline in luminous flux. Normally a value of 0.8 is applied, which means that over the life cycle of the system, the initial luminous efficacy of 100% will drop down to 80%. Telemanagement systems compensate for this decline by initially operating the lighting equipment in a dimmed state. This prevents the illumination being too bright and dependent on the system, saves between 8% and 10% in energy. When planning a road lighting system, the required lighting level, the luminaire spacing and the uniformity of the lighting are decisive factors when determining the required power rating of the lamps. If the result matches the offered spectrum, in most cases those responsible for the lighting planning will choose the next higher wattage level, in order to guarantee safety on the streets. The telemanagement system compensates for the oversizing and for instance, dims a 150 W lamp down to the required 120 W. This intelligent intervention reduces energy consumption by up to 25%,

lowers CO<sub>2</sub> emissions, improves reliability and minimises maintenance costs. The advantages at a glance:

- Energy saving
- Energy regulation
- Efficient maintenance
- Less greenhouse gases
- Improvements in reliability and safety

[43] Telemanagement brings a raft of benefits in public domains. For example, the first so-called "master" luminaire that is equipped with a twilight sensor, controls all the other "slave" luminaires that it is networked with. The deployed technology can switch luminaires on and off and dim them, gather consumption data and transfer this to a central computer.

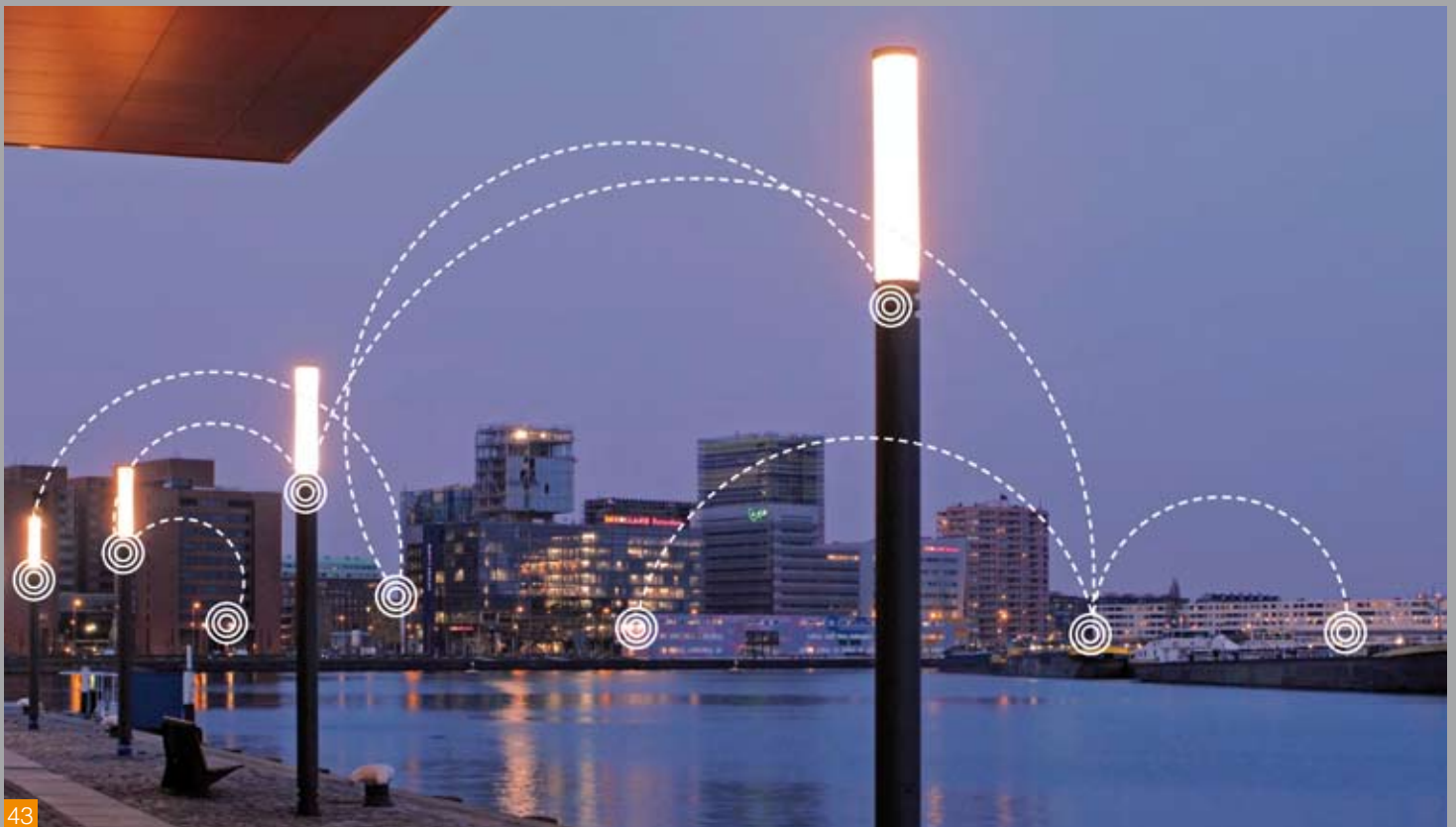

# Lighting planning basics

Lighting is no longer just used by local authorities to guarantee safety in public spaces. Increasingly, this medium is used to create an attractive urban image. Under the guidance of the lighting planner, the lighting master plan brings all the complex demands together to produce a single, holistic result.

Light, as a tool, has significantly increased its value in the past years, when it comes to designing public spaces. The joint goals of achieving an attractive urban landscape and of protecting the environment through the minimising of light immissions and CO<sub>2</sub> emissions make heavy demands on lighting planning. As a result, lighting master plans are becoming more ambitious and more complex. Today, when a local authority chooses the design medium of light, certain basic perceptions are already in place and are reason enough for commissioning a lighting master plan.

Urban planning offices, public works departments or local authorities turn increasingly to lighting designers or lighting planners with their experience of identifying the complexity of the lighting and design demands and their ability to convert these into a holistic lighting solution. The various lighting zones and functional areas are represented clearly in a lighting master plan. This defines the guidelines for the illumination of a town, takes local characteristics into account and combines

lighting themes. As well as the design specifications, the lighting master plan also includes details of the economic and technical aspects.

New lamp technologies and luminaires with optimised light control form the basis for ambitious and effective light stagings that also exhibit a high degree of cost economy. New lighting sources such as light emitting diodes (LEDs) are now showing their potential in the exterior lighting, while at the same time requiring much less energy and lasting much longer than conventional lamps. Particularly the possibility of stepless dimming through lighting control systems, fulfils a pre-requirement for producing dynamic lighting experiences.

Essential points have to be analysed and taken into account before embarking on the creation of a lighting master plan:

- An analysis of the current situation in order to develop a concept
- Feasibility and financing
- Breaking the concept down into phases
- Lighting and design approach
- The cost-effectiveness of illumination systems

The illumination of architecture calls for a close collaboration with the client during the planning stage and also in the case of historic buildings, with the Heritage Commission. Various conditions have to be clarified to start with, for example:

- What design statement should be communicated to the observer about the architecture and its immediate surroundings
- Main lines of sight and/or the principal angle of viewing for the passers-by
- Form and architectural characteristic of the object, such as surfaces, curves or cornices
- Surface characteristics such as structure, colour, etc.
- The structural environment
- Necessary measures for avoiding glare for road users
- Measures to minimise disturbing light immissions
- Ways to minimise disturbing influences on the character of neighbouring buildings

Required average luminance on the object being illuminated (based on different ambient conditions)

Position of the object	Average luminance on the object
Free-standing	3 to 6,5 cd/m <sup>2</sup>
In built-up, dark surroundings	6,5 to 10 cd/m <sup>2</sup>
In built-up, semi-bright surroundings	10 to 13 cd/m <sup>2</sup>
In built-up, bright surroundings	13 to 16 cd/m <sup>2</sup>





45

Recommended minimum values for illuminance levels, in line with CIE Publication 94:1993  
 These are guide values that have to be adjusted to the corresponding local conditions

Material and colour of the surface to be illuminated	Ambient brightness		
	Low	Medium	High
Light stone, light marble	20 lx	30 lx	60 lx
Semi-light stone, concrete, cement, lightly coloured marble	40 lx	60 lx	120 lx
Dark stone, grey granite, dark marble	100 lx	150 lx	300 lx
Light yellow bricks	35 lx	50 lx	100 lx
Light brown bricks	40 lx	60 lx	120 lx
Dark brown bricks, red granite	55 lx	80 lx	160 lx
Red bricks	100 lx	150 lx	300 lx
Dark bricks	120 lx	180 lx	360 lx
Architectural concrete	60 lx	100 lx	200 lx
Natural aluminium	200 lx	180 lx	600 lx
Heavily coloured surfaces ( $\rho = 10\%$ )	120 lx	180 lx	360 lx
Moderately coloured surfaces ( $\rho = 30-40\%$ )	40 lx	60 lx	120 lx
Pastel coloured surfaces ( $\rho = 60-70\%$ )	20 lx	30 lx	60 lx

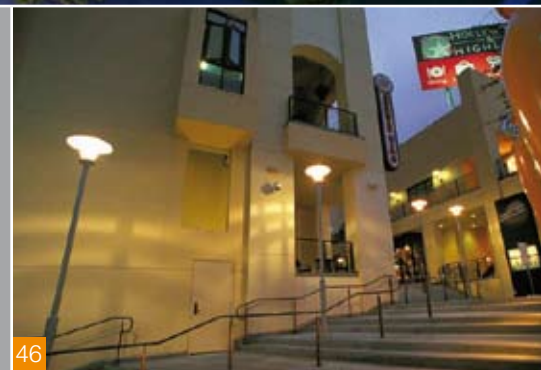

46

[44] The combination of lighting both close to and removed from the building and light coming from the interior, give the Reichstag building in Berlin the effect of a sculpture.

[45] The effects of light and shade that result from the deployment of different lighting tools, elaborates the details of the architecture and draw the gaze of the observer to it.

[46] Column luminaires with a medium mounting height don't only provide orientation and safety for the paths of the city centre. They also create an attractive urban landscape.

### Media to support the planning effort

Today, through the use of light calculation software and professional computer visualisation, the details of the different versions of lighting concepts can be illustrated exactly, almost in photographic quality. These tools help the lighting planner to simulate illumination scenarios and brightness distribution. 3D computer simulations have proved to be an indispensable and essential medium, particularly for complex lighting master plans.

This becomes clear with the illumination of a facade: The more layered, for example, the facade of a church is, the more cost-intensive a 3D simulation becomes. Alternatively, a digitalised picture of the building in question can be used, in order to demonstrate the different lighting effects using an image editing program. A test illumination on a part of the facade using different lighting positions, achieves

very realistic impressions. Here, you can also test the lighting effects using different lamps and lenses.

### Lighting level

One of the most important criteria for an attractive urban landscape is the lighting level. In contrast to interior lighting, planning for exterior lighting is based on the luminance. This is decisive when it comes to making an area, like the facade of a building or a street or an enclosed space like tunnel, visible. The luminance is determined by the illuminance and the reflective properties of the surfaces to be illuminated. The illuminance depends on the number and position of the light sources as well as their power. The CIE publications 94:1993 and 136:2000 Minimum lighting strengths, are recommended as an aid to the planner. They take into account the degree of reflection, determined by the material and colour of

the surfaces to be floodlighted. This has a considerable influence on the perception of an object that has a mainly matt surface. The same is true for the background and/or ambient brightness as well as the resulting contrasts.

The effect of the building is made that much more impressive, the more it stands out from its background. The illumination of a tower standing in the middle of an illuminated town calls for a higher illuminance than would be the case with a dark background, as with a castle standing on its own in the middle of the countryside. The darker the surface the lower the degree of reflection and therefore the brighter the illumination that must be used for the object, i.e. the illuminance must be raised accordingly.

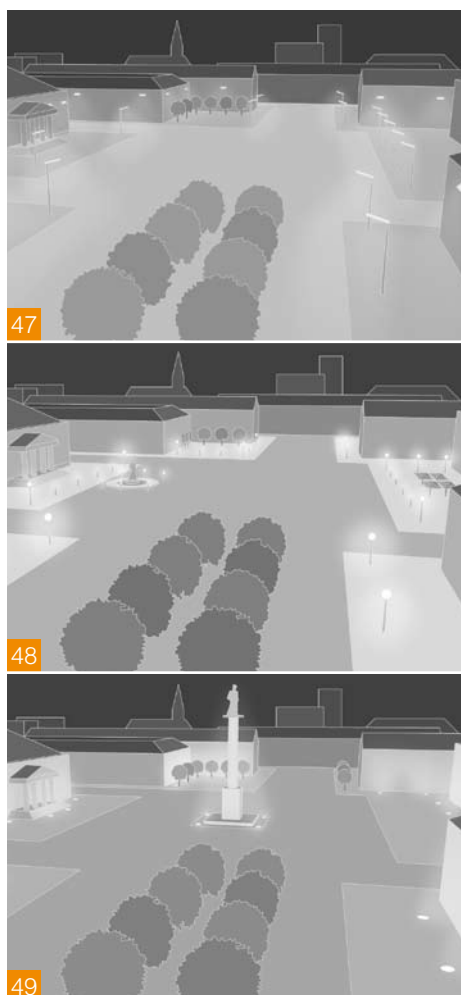

### Illumination of squares

**Carpet of light [47]:** The square is uniformly illuminated through the lights situated at the edge of the square, guaranteeing safety. There is no glare for the passers-by as the mounting height is outside their field of vision. The facades are only floodlighted by scattered light. As a result, the area doesn't display any particular eye-catcher.

**Zones of light [48]:** A pleasant atmosphere can be achieved through the fact that numerous, zonally-grouped low-level light points give the square a structure. These bright zones draw the passers-by in and as a whole, cause more people to frequent the square. In this case, because of the mounting height, the upper part of the facades of the surrounding buildings remain in darkness and retreat into the background.

**Islands of light [49]:** The square itself has a subordinated importance and therefore, is only illuminated through individual light points. The "principal actors" are the facades of the buildings at the edge of the square, that are staged through targeted illumination. As a result, the architectural elements of the building fronts can be elaborated in detail.

The illuminance  $E$  (lx) and the degree of reflection of the surface  $\rho$  are used in the calculation of the luminance  $L$  (cd/m<sup>2</sup>), as shown in the following formula:

$$L = \frac{E \cdot \rho}{\pi}$$

The luminance and therefore the impact of the illuminated building or monument are significantly influenced by the degree of reflection, which decreases through the effect of pollution. However, the effect of pollution is reduced, the darker and rougher the characteristic of the original material. Accordingly, the illuminance must be adjusted in order to achieve the same luminance and/or the same perceptive impression.



50



51



52

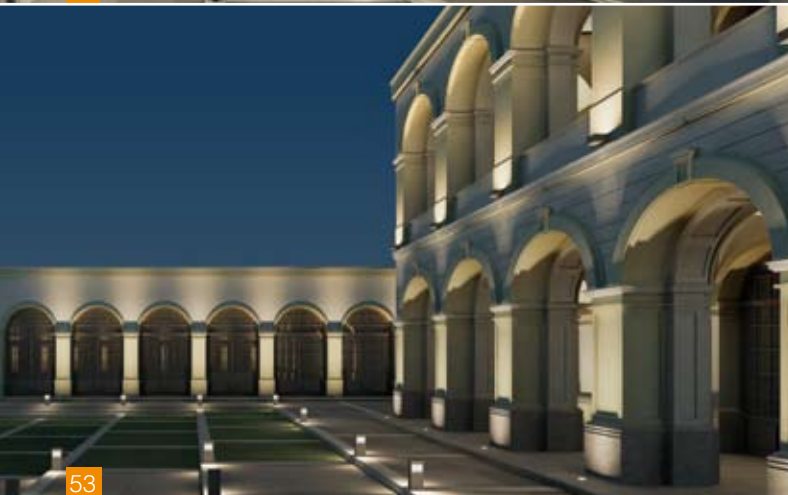

53

## Facade illumination

Reflectors and lenses [50, 51]: Recessed ground luminaires prove to be a very versatile tool for exterior lighting, because the emission characteristics and the light effects can be changed just by the use of reflectors and lenses. Installed close to the wall and with asymmetrical, wide-angle characteristics, such lights are well suited for flooding the wall with uniform light distribution, to represent the vertical surface as a space-creating element. If the focus of the brightness is set at about eye level, important elements on the wall can be given special emphasis while at the same time illuminating the whole surface. Sided light emanating from recessed ground luminaires with asymmetric spot characteristics, don't just illuminate a wall but they also elaborate material and surface structures. Recessed ground luminaires with rotationally symmetrical emission characteristics that are integrated into access paths, take on an orientation function. Together with bollard luminaires, an attractive lighting atmosphere can be achieved that gives bright accents to the building and that increases safety.

The effects of light and shade [52, 53]: Particularly with the illumination of the facades of historical buildings, there are a lot of ways of catching the attention of the observer. Crucial for the selection, is the light effect you are seeking to achieve. An areal illumination of the surface of the building can be achieved by installing spotlights or floodlights at some distance from the building, perhaps on a neighbouring building or a high column. Details such as cornices and plastering can be elaborated with lights installed close to the building. Directed light from recessed ground luminaires or spot-beaming floodlights is limited just to the particular detail and the surroundings remain dark. Also, lighting from inside can add to the effect in order to emphasis windows or arcade arches. But only the combination of illumination from a distance and close to the building that leads to the dynamic effects of light and shade.

# Lighting special: Luminaires

The lighting effects that can be achieved are as versatile as the light sources and luminaires that are available for use outdoors. Wide-angled, accentuating, neutral or in colour: targeted deployment is a pre-condition for achieving an attractive urban landscape.

The selection of the luminaire depends principally on the specific lighting task and on the desired lighting effect. The illumination of streets, footpaths and cycle tracks calls for different lighting tools than those required, for example, for illuminating facades or for the theatrical staging of monuments or fountains. Design also plays a role as the shape of a luminaire

should correspond both to the architecture and its environment, particularly when it is switched off. Technical properties, quality and safety are also important when making the choice.

Lamps and lighting technology are the critical criteria for achieving the required lighting effect. Directing the beam of light

upwards should be avoided, in order to minimise light immissions.

There is a close connection between the decisions for a light source or for a luminaire. The selection of specific lamp or an LED module can limit the range of possible types of luminaires. The same applies in the opposite direction that the choice of





a particular luminaire can restrict your options when it comes to the available lamps. For exterior lighting, the lights of choice are high-pressure sodium vapour lamps and metal halide lamps, but compact fluorescent lamps and fluorescent tubes are also popular. Nowadays, LED modules are also gaining a wider acceptance and not just for illuminating footpaths and cycle tracks but also for standard-compliant road lighting. LEDs also show their abilities when it comes to producing impressive colour effects.

[a] Floodlights and spotlights with asymmetrical, symmetrical or rotational-symmetrical light distribution and floodlights mounted on buildings or columns are ideally suited for large surface illumination from a distance.

[b] Recessed ground luminaires with asymmetrical light distribution highlight vertical surface with sided light. Versions from narrow- to wide-angle are available for achieving differentiated lighting effects.

[c] Recessed ground floodlights with rotational-symmetrical light distribution illuminate trees and shrubs from below, thereby setting bright accents in gardens or parks, for instance.

[d] As well as conventional lamps and LEDs, fibre-optic lighting systems also provide coloured or white light effects when used in underwater floodlights. The surface of the water gives movement and fountains provide enchanting effects built around light and colour.

[e] Wall-mounted lights, whether surface or recessed, facilitate orientation, for example with staircases or steps, thereby increasing safety. They also create a pleasant atmosphere.

[f] Wall-mounted dual lights, with a spot beam of light upwards and a wide-angle beam directed downwards, accentuate a facade and attract the gaze of passers-by.

[g] Wall-mounted lights, installed directly on the facade emphasize the architectural elements and therefore the character of a building. A spot-beaming light distribution limits the focus of the light on the details and the surrounding area remains dark. The resulting contrast gives a charming, theatrical effect.

[h] Media façades with their coloured LEDs that can be controlled individually, captivate through their dynamic presentation, showing for instance video sequences or advertising messages and are becoming real crowd-pullers.

[i] Linear recessed ground luminaires, also available in colour, can be used as light tracks to define areas in larger squares. Providing the lights with an opalescent cover to defuse the light beams, minimises the glare for passers-by.

[j] Lines of LED lights around the edge of a building's roof, whether static with monochrome coloured lights or dynamic with alternating colour sequences, are sure to provide pulling power, even from a distance.

[k] When used as path lighting, bollard lights give orientation and security in parks and green spaces. And because of their targeted light control, they don't create any scattered light.

[l] Arcades, passages and the like can be given atmospheric lighting with ceiling-mounted lights, whether surface or recessed. The contrast to the darker facades opens up the possibility for creating theatrical effects.

[m] Column luminaires with secondary lighting technology, so-called projector-reflector lighting systems, stand out on the one hand by providing a non-glare, homogeneous illumination for pedestrian zones and city-centre squares and on the other hand for the ease with which the lamps can be exchanged.

[n] Decorative column luminaires with relatively low mounting heights are suitable for the illumination of footpaths and cycle tracks as well as for the illumination of squares.

[o] Column luminaires with mirror optics, that is to say with downward-directed light distribution and optimised light efficiency, are well suited for standard-compliant and energy-efficient road lighting.

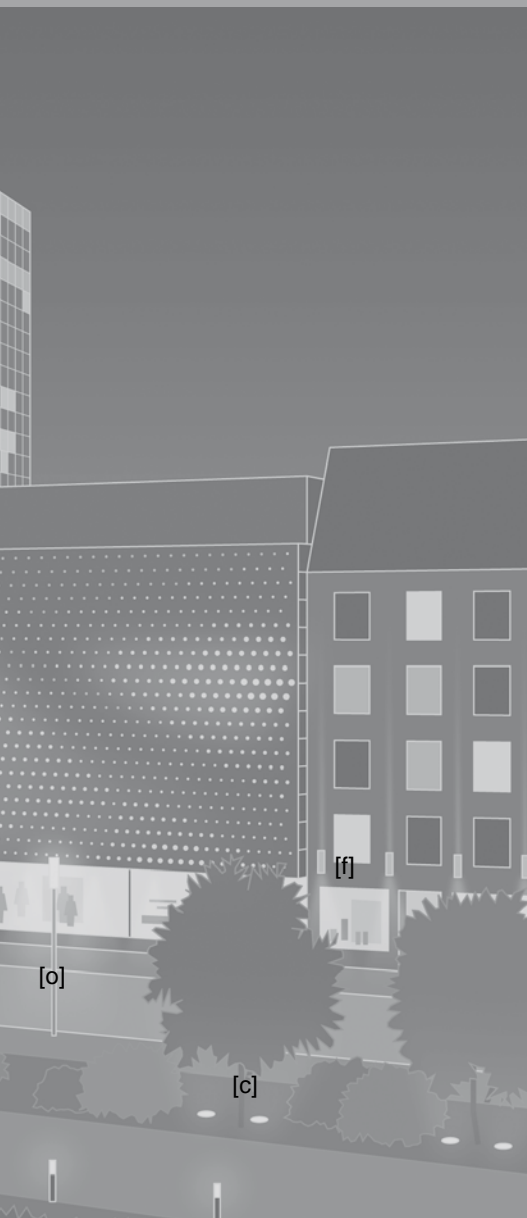

# LED - Technology of the future

Coloured or white, inside or outside: LEDs are on the upswing. As a module in many different forms or as an attractive designer luminaire, the semi-conductor light is proving its potential, also in terms of energy-efficiency and sustainability.

130 years after the invention of the light bulb, LED technology is bringing about a huge breakthrough in the world of lighting. Very rapidly, the semi-conductor light has developed from being principally a niche product to become an interesting component to address the demands placed by architectural lighting. A wide range of monochrome colours, dynamic colour sequences based on RGB colour mixing with high-performance LEDs in the three base colours of red, green and blue as well as a classical white light, prove their potential not just for accented lighting but also now for general lighting. The Ecodesign Directive 2009/125/EC (ErP) has also provided an impulse for the growing proliferation of these attractive and energy-efficient light sources.

Emerging technologies will also add further improvements to the compact light emitting diodes, LEDs. With each generation, the luminous efficacy and colour homogeneity increase with reduced energy consumption and longer working lives, currently up to 50,000 hours, depending on the LED type, operating voltage and the thermal management in the light. Miniaturisation and falling prices are also factors, because the development of component LEDs follows the demands of the semi-conductor industry. The trend that has developed in the past of a drop in costs by a factor of 10 every decade, accompanied by an increase in luminous flux by a factor of 20 during the same period, seems to be progressing unabated.

The LED modules that are already available on the market provide an excellent basis for innovative applications, both indoors and outdoors. When connected up together and equipped with application-specific lenses, the floodlights, linear lights, ribbon lights or spot lights are very well suited for backlighting diffuse surfaces, for emphasising contours or for

integration, even in filigree lamps. LED lamps can also demonstrate their ability when used for exterior lighting, in a one-to-one exchange for conventional lamps. But also the other characteristics that the LEDs have inherited from the semi-conductor world, such as shock and vibration resistance, make an impact. Through the lack of IR and UV emissions, this light source is particularly suitable for the illumination of sensitive museum exhibits or for lighting fabrics or leather goods. A further plus point is the excellent operational performance of LEDs at low temperatures, even at temperatures below zero. The luminous efficacy is maintained and the specified luminous flux is available immediately at switch-on. This makes the semi-conductor light a sure candidate for exterior lighting. Particularly, the rapid development of LED lights for general lighting is affected by the advances made with white light. New colour conversion ideas, that is to say the combination of blue LEDs with manufacturer-specific, often patented bulbs to make white, can lead to an increase in efficiency with warm-white LED light with a colour temperature in the range from 2,500 K to 3,500 K, which can be controlled within the lamp, on a task-specific basis if required. Typically, this demonstrates a luminous efficacy reduced by some 30% in comparison to LEDs with 6,500 K colour temperature, i.e. cool daylight white.

In the last five years, the efficiency of white LEDs has trebled so that the luminous efficacy is between 80 lm/W and 100 lm/W. As a result, LED solutions are now a viable alternative to low-voltage halogen lamps or compact fluorescent lamps. They deliver the twin benefits of significant energy savings and a reduction in CO<sub>2</sub> emissions.

Nowadays, the luminous efficacy is enough not just for providing standard-compliant illumination for footpaths, cycle tracks and car parks, but also for streets. In this case, the use of efficient optics provides the required uniformity. When integrated into a forward-looking light management system, the lighting level can be adjusted to current requirements, for example the weight of traffic or weather conditions.

LED lights for outdoor deployment deliver an additional effect that is even more relevant for the environment. The use of 3D lenses instead of optics with reflectors as with conventional lamps, increases the efficiency of the luminaires. At the same time, there is a reduction in light emissions so that practically no scattered light is generated.

The quality of both the white LED light and the full-bodied colours are set to ensure the continued and increasing popularity of these innovative semi-conductor solutions. Because they offer scope for creativity. On the one side there are the compact dimensions and on the other the simple possibilities to dim and control in order to produce grandiose, atmospheric colour sequences, delivering impressive scenarios and creating spatial impact and atmosphere. As a result, because of the energy efficiency of such LED applications, aspects such as environmental protection and sustainability are gaining in importance. LED light is certainly showing itself to be an exceptionally attractive option in all relevant application areas. However it should not be overlooked that only high-quality LED modules and LED lamps guarantee the described properties such as light quality, length of working life and energy efficiency. In much the same way as happened with energy-saving lamps, an apparently economical solution, for example from the Far East, often turns out to be a disappointing, cheap product.



55



56



57

[55] LED modules are classified as the light source of the future. The trend has already started as the wide range of options on offer proves.

[56] The urban landscape is not just defined by the light provided by exterior lighting but also by the light, some of which is coloured, that shines out from the interiors of buildings.

[57] LEDs are a source of inspiration for creative ideas, for designers and urban planners.

[58] Coloured lines of LED light provide contrasting accents to the otherwise, understated illumination of the architecture.



58



59

Lamp type		T8 fluorescent lamps Ø 26 mm	T5 fluorescent lamps Ø 16 mm	2 or 4 tube lamps, elongated construction	3 or 4 tube lamps, compact construction	Single-end mounting with ceramic technology	Double-end mountings with ceramic technology	Double-end mountings	Tubular shape with quartz technology	Tubular shape with ceramic technology	Ellipsoidal shape	Tubular shape
		1	2	3	4	5	6	7	8	9	10	11
		Tube-shaped fluorescent lamps		Compact fluorescent lamps		Metal halide lamps				High-pressure sodium vapour lamps		
Lamp power rating (rated power in W)	from to	14 70	14 80	8 80	60 120	20 400	70 250	1.000 2.000	250 2.000	45 315	35 1.000	50 1.000
Luminous flux (lm)	from to	860 6.200	1.100 6.150	250 6.000	4.000 9.000	1.600 46.000	5.100 25.000	90.000 230.000	18.000 240.000	4.300 37.000	2.200 128.000	4.400 130.000
Luminous efficacy (lm/W)	from to	61 93	67 104	46 90	67 75	80 100	73 100	86 115	80 120	96 120	63 139	70 150
Light colour		ww, nw, tw	ww, nw, tw	ww, nw, tw	ww, nw	ww, nw	ww, nw, tw	nw, tw	nw, tw	nw, tw	ww	ww
Color rendering index R <sub>a</sub> (some given as a range)		80-96	80-93	80-90	80-85	80-95	80-85	60-95	60-90	60-90	25, 65	25, 65
Socket		G13	G5	2G11 2G7	2G8-1	G8,5 G12 G22 GU6,5 GU8,5 PGJ5	RX7s FC2	special	E40	PGZ12 PGZ18	E27 E40	E27 E40

# Lighting special: Light sources



14



15



16

## Fluorescent lamps [1, 2]

Fluorescent lamps stand out through their high luminous efficacy, good colour reproduction and long working life. Particularly working with electronic ballasts (a must with T5 lamps with a 16 mm diameter), improves energy efficiency and light quality. Versions especially developed for use outdoors demonstrate their good properties, delivering a constant, high luminous flux over a wide range of temperatures from 5° C to 70° C. Both T5 and T8 fluorescent lamps (with 26 mm diameter) can be dimmed through the use of suitable ballasts.

## Compact fluorescent lamps [3, 4]

Compact fluorescent lamps offer the same characteristics as fluorescent lamps but because of their compact form, they can be integrated into other light designs. As a result, models that are developed for exterior lighting also stand out with a constant high luminous flux over a wide temperature range and a long working life. The last point is an advantage as the exchange of lamps in this area can be a very involved and time-consuming procedure.

## Metal halide lamps [5-9]

The brilliant light produced by metal halide lamps has always been a convincing argument, making them the lamps of choice for creating an attractive urban image. With their even higher luminous efficacy of up to 100 lm/W, lamps designed with ceramic burner technology have shown themselves to be clearly more energy-efficient, particularly for the requirements of urban lighting. The white light with 3,000 K colour temperature provides non-glare light control on the streets for more safety and for the staging of monuments. Through the use of the same dimensions and socket, metal halide lamps are a good substitute for inefficient high-pressure sodium vapour lamps.

## High-pressure sodium vapour lamps [10, 11]

The new generation of high-pressure sodium vapour lamps with ceramic burners and an ellipsoidal outer bulb can be used to replace inefficient high-pressure mercury vapour lamps without having to make any modifica-

tions, thereby saving up to 20% energy at the same level of luminous flux. With a working life of up to 28,000 hours, high-pressure sodium vapour lamps are marked out for deployment in public and urban areas.

## LED lamps [12]

LED lamps are available these days in many bulb shapes and with all socket designs imaginable. With working lives of up to 30,000 hours, they offer themselves as extremely durable and energy-efficient substitutes for conventional lamps.

## LED modules [13-16]

Because of advances made with light yield, LED modules, consisting of LEDs, wide-angle lenses and reflectors, can be considered as being the forward-looking solution for technical and decorative illumination in the public domain. Alongside energy-efficiency and long working life, the essential advantage for LED road lighting lies in its aligned light. This means that all requirements, that is to say standard-compliant, homogeneous and strictly focussed illumination are completely filled without producing any scattered light. To an extent, using adjustable illumination limits, the scattered light can also be controlled up to a strictly defined line. LED modules also demonstrate superior characteristics in their operating behaviour at cool ambient temperatures.

The trend towards standardisation even facilitates the exchange of the lamp at the end of its working life. Additionally, LED modules can also be exchanged long before they reach the end of their working life, by a more efficient product generation. This means continued standard-compliant illumination at a then significantly reduced energy consumption. With the available range of light colours, LED solutions are a viable alternative for all conventional lamps in outdoor applications.

LED lamp	LED module	LED module	LED module	LED module
12	13	14	15	16
LED-lamps	LED modules			
3	23	15	30	30
7		28		314
90	900	1,100	970	1,680
806	1,220	3,000	1,300	23,800
37	39	72	32	84
46	53		43	
ww, tw	ww, nw, tw	ww, nw	nw, tw	ww, nw, tw
>80	70 80	>70	70 80	>80
E14 E27	-	-	SLA1- Socket	-

ww = warm white Colour temperature under 3,300 K  
 nw = neutral white Colour temperature from 3,300 K to 5,300 K  
 tw = daylight white Colour temperature under 5,300 K

# licht.de publications

Each booklet!

€ 9,-



## licht.wissen 15 Good Outdoor Lighting for the Home

40 pages that answer questions about good outdoor lighting for the home and conservatory. Booklet 15 gives many practical tips and ideas on how to provide the correct lighting for home and garden, while at the same time ensuring a correctly functioning and safe environment.



[licht.wissen 01] 60 pages of information about artificial lighting: Booklet 1 describes the physical components of light and conveys a knowledge of the basics of modern lighting technology.

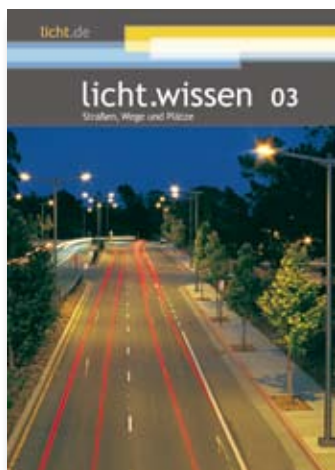

[licht.wissen 03] 40 pages on road lighting: Booklet 3 describes how "seeing and being seen" works and explains how road accident figures and crime rates can be reduced.



[licht.wissen 08] 64 pages of information about the correct illumination for sport and leisure facilities, both indoor and outdoor. It covers lighting quality criteria, energy-efficient lights and even emergency lighting.



[licht.wissen 13] 32 pages of information about lighting for outdoor workplaces. Booklet 13 explains which criteria have to be taken into account when illuminating outdoor workplaces. It is based in part on the European lighting standard DIN EN 12464, Part 2.

## licht.wissen in English – Free pdf downloads from [www.all-about-light.org/en/publications](http://www.all-about-light.org/en/publications)

- |                                                                    |                                                    |                                                                |
|--------------------------------------------------------------------|----------------------------------------------------|----------------------------------------------------------------|
| 01 Lighting with Artificial Light (2008)                           | 07 Good Lighting for Health Care Premises (2004)   | 14 Ideas for Good Home Lighting (2009)                         |
| 02 Good Lighting for Schools and Educational Establishments (2003) | 08 Sport and Leisure (2010)                        | 15 Good Outdoor Lighting for the Home (2009)                   |
| 03 Roads, Paths and Squares (2007)                                 | 09* Prestige lighting (1997)                       | 16 City Marketing with Light (2010)                            |
| 04 Good Lighting for Offices and Office Buildings (2003)           | 10 Emergency lighting, safety lighting (2008)      | 17 LED: The Light of the Future (2010)                         |
| 05 Industry and Trade (2009)                                       | 11 Good Lighting for Hotels and Restaurants (2005) | 18 Good Lighting for Museums, Galleries and Exhibitions (2006) |
| 06 Good Lighting for Sales and Presentation (2002)                 | 12 Lighting Quality with Electronics (2003)        | 19 Impact of Light on Human Beings (2010)                      |
|                                                                    | 13 Outdoor Workplaces (2007)                       |                                                                |

\* Currently out of print

# All about light!

## Impartial information

licht.de provides information on the advantages of good lighting. licht.de offers a great deal of material on every aspect of artificial lighting and its correct usage. The information provided is impartial and based on current DIN standards and VDE stipulations.

## licht.wissen

The booklets 1 to 19 of the licht.wissen series of publications (formerly: Information on Lighting Applications) are designed to help anyone involved with lighting – planners, decision-makers, investors – to acquire a basic knowledge of the subject. This facilitates cooperation with lighting and electrical specialists. The lighting information contained in all these booklets is of a general nature.

## licht.forum

licht.forum is a specialist periodical focusing on topical lighting issues and trends. Generally around 12 pages long, it is published at irregular intervals.

## www.licht.de

licht.de also presents its knowledge of lighting on the Internet. Its website www.licht.de features a "Lighting for the Home" portal and a "Lighting for Professionals" section offering practical tips for private and professional lighting applications.

"Lighting Know-how" offers one-click access to explanations of technical terms. A database containing a wealth of product overviews, a supplier matrix and details of the addresses of licht.de members provide a direct route to manufacturers and their products. "Info and Service" round off the Internet presence with an online shop for print publications and downloads, links to "Lighting on the Web", FAQs and an extensive lighting glossary.



## Imprint

### Publisher

licht.de  
Fördergemeinschaft Gutes Licht  
Lyoner Straße 9, 60528 Frankfurt am Main  
Tel. 069 6302-353, Fax 069 6302-400  
licht.de@zvei.org, www.licht.de

### Editorial office

LightAgentur, Bonn  
Ursula Sandner, Heusenstamm

### Design, Realisation

LightAgentur, Bonn

### Editing

Christiane Kersting, Lüdenscheid

### Printing

- no print -

ISBN-No. PDF edition 978-3-926193-63-6

05/10/00/16II

The publication takes account of current DIN standards (available from Beuth Verlag, Berlin) and VDE stipulations (available from VDE Verlag, Berlin).

Full or partial reprints of licht.wissen 16 with the permission of the publishers.

### Acknowledgements for photographs

Numbering of photos on back page:			60
61	62	63	
64	65	66	

### Photographs

[1, 6, 7, 11, 12, 45] Michael Batz, Hamburg; [14-19, 21-32] Uwe Knappschneider, Wuppertal; [34, 36, 41] Ulrike Brandt Licht, Hamburg; [40] Frank Alexander Rümmele, Alfter; [35, 37, 38] Jörn Hustedt for Ulrike Brandt Licht, Hamburg [59] Blitzwerk, Mühlital and LSD, Darmstadt

All other images, 3D visualisations and graphics originate from licht-de associate companies or were prepared at the request of licht.de.

licht.wissen 16  
City Marketing with Light



licht.de

Förderungsgemeinschaft Gutes Licht  
Lyoner Straße 9  
60528 Frankfurt am Main  
Germany  
phone +49 (0)69 63 02-353  
fax +49 (0)69 63 02-400  
licht.de@zvei.org